



N-CNG Series CNG Nozzles

Applications

Fast fill public and private CNG stations



N-CNG P30 (blue) CNG Nozzle with a Type 3 Handle
N-CNG P36 (yellow) CNG Nozzle with a Type 3 Handle

Materials

Item	Part	Material
1	Body	Aluminium
2	Swivel	Stainless Steel
3	Nozzle	Stainless Steel
4	O-rings	Elastomer
5	Springs	Stainless Steel

Item	Part	Material
6	Nozzle Segments	Stainless Steel
7	Cover	Plastic
8	Handle	Aluminium
9	Lever	Aluminium

Product Information

Product tested and certified to ANSI NGV1:2017 and ISO 14469:2017

JIC end connections are standard configuration and can be removed to access same-size standard SAE ports that conform to SAE J1926-1

Custom adaptors can be supplied to suit your application

All products are manufactured to ISO 9001 standards

Features & Benefits

High flow design allows faster and more complete filling

Ergonomic, light weight and easy to use

Visual coupled indicator

Lever locking handle gives peace of mind for secured connection

Smooth acting 360° twin hose swivel



N-CNG Series CNG Nozzles

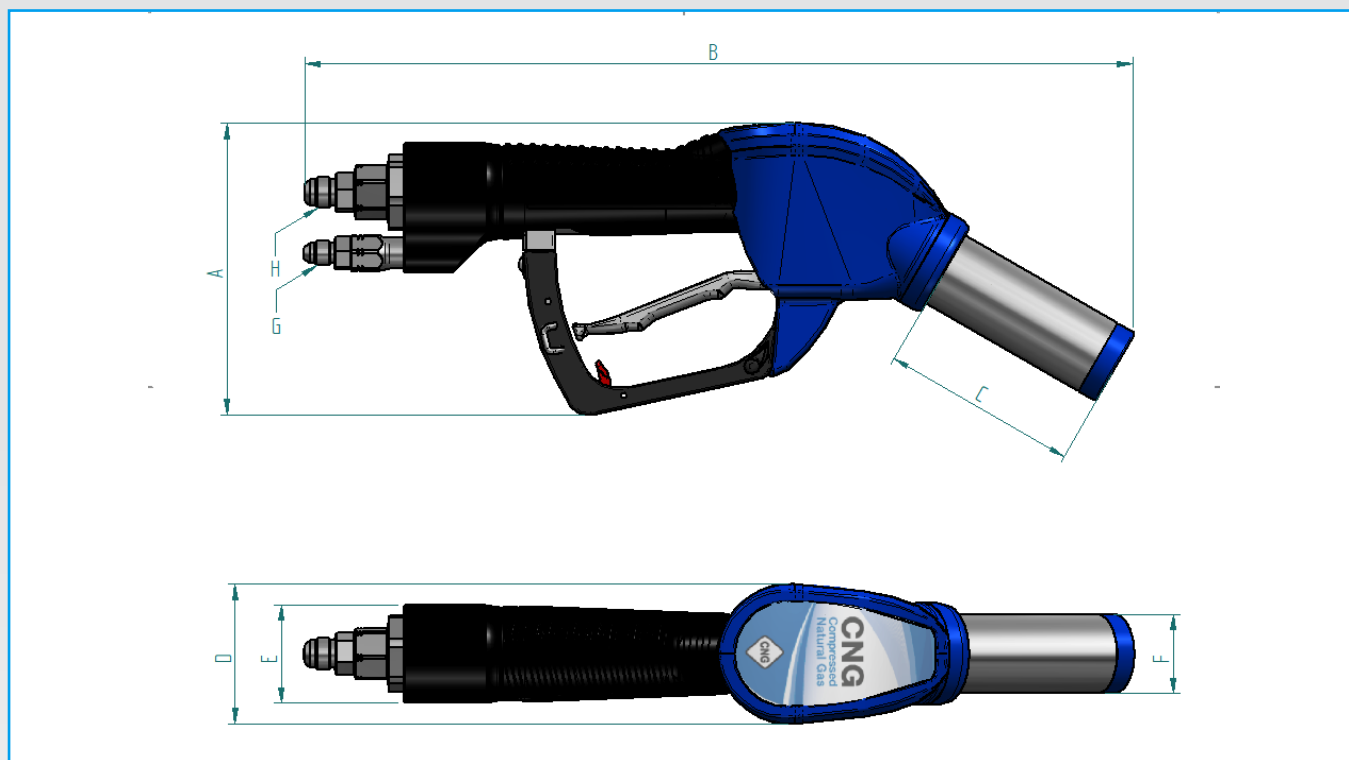

Product Specification

Part Code	Colour	Mass lb (kg)	Service Pressure bar (psi)	Min. Operating Pressure bar (psi) *	Max. Allowable Working Pressure bar (psi) **	Min. Temp. °F (°C)	Max Temp. °F (°C)	Cv
N-CNG P30	Blue	3.7 (1.7)	207 (3000)	5 (72.5)	312.5 (4532)	-40 (-40)	185 (85)	1.0

* Minimum pressure at which product will operate optimally

** The maximum allowable pressure at which the product can operate

Dimensions Inch (mm)

Part Code	Size	A	B	C	D	ØE	F	G (Vent Thread)	H (Inlet Thread)
N-CNG P30-J3MILAA [§]	3/8"	5.3(134.1)	14.9(377.6)	3.8(96)	2.5(64)	1.8(45)	1.4(36)	1/4" JIC [†]	3/8" JIC [‡]

[§] Type 3 handle as shown in image

[†] May be removed to access 1/4" SAE port

[‡] May be removed to access 3/8" SAE port



N-CNG Series CNG Nozzles

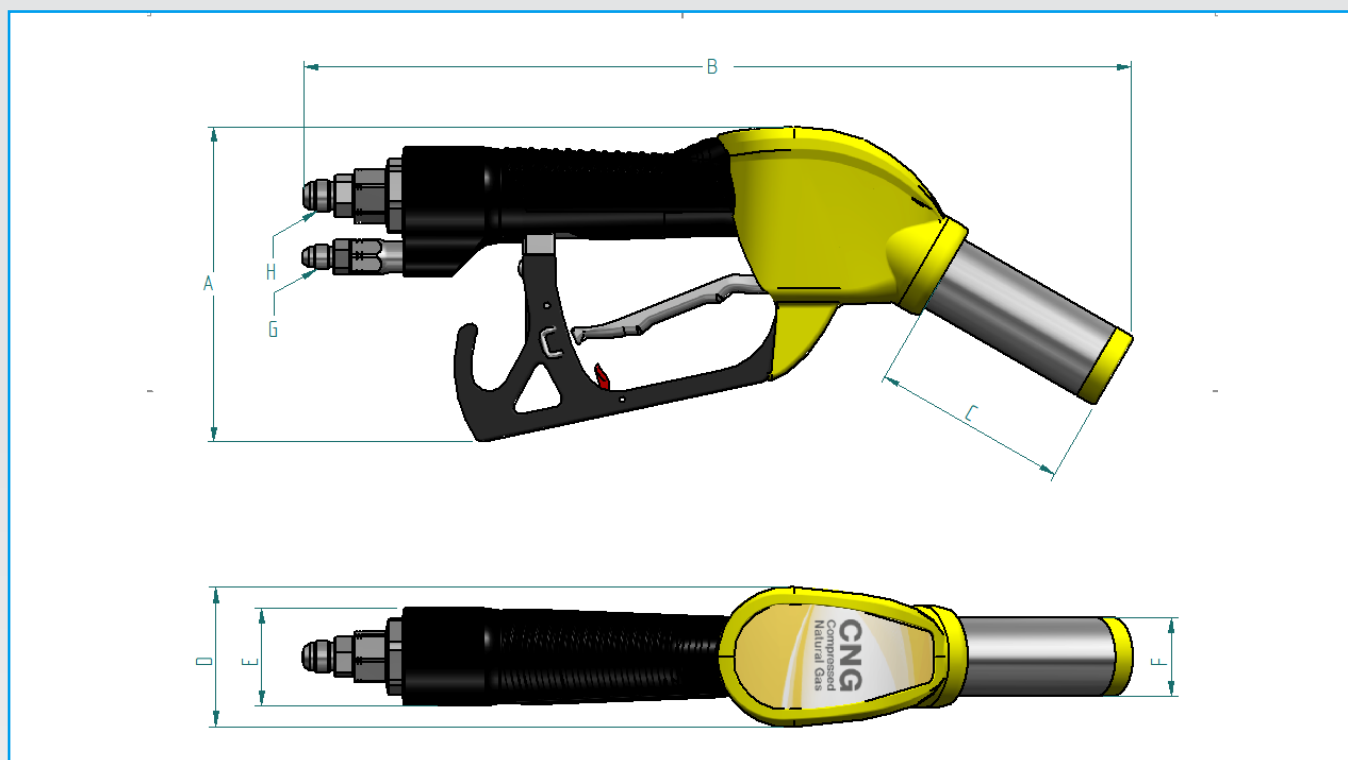

Product Specification

Part Code	Colour	Mass lb (kg)	Service Pressure bar (psi)	Min. Operating Pressure bar (psi) *	Max. Allowable Working Pressure bar (psi) **	Min. Temp. °F (°C)	Max Temp. °F (°C)	Cv
N-CNG P36	Yellow	3.7 (1.7)	250 (3626)	5 (72.5)	312.5 (4532)	-40 (-40)	185 (85)	1.0

* Minimum pressure at which product will operate optimally

** The maximum allowable pressure at which the product can operate

Dimensions Inch (mm)

Part Code	Size	A	B	C	D	Ø E	F	G (Vent Thread)	H (Inlet Thread)
N-CNG P36-J3MILCB***	3/8"	5.3(134.1)	14.9(377.6)	3.8(96)	2.5(64)	1.8(45)	1.4(36)	1/4" JIC †	3/8" JIC ‡
N-CNG P36-J4MILCB [§]	3/8"	5.7(144)	14.9(377.6)	3.8(96)	2.5(64)	1.8(45)	1.4(36)	1/4" JIC †	3/8" JIC ‡

*** Type 3 handle as shown on P30 nozzles on pages 1 and 2

[§] Type 4 handle as shown in image

† May be removed to access 1/4" SAE port

‡ May be removed to access 3/8" SAE port