

Oasis



BV700 Series Ball Valve Code 62 Instruction Manual

▲ WARNING

Failure to follow these instructions or to properly install and maintain this equipment could result in gas leakage, fire or explosion causing property damage and personal injury or death.

Oasis products must be installed, operated and maintained by trained and competent personnel in accordance with all applicable local codes, rules and regulations in addition to the Oasis Instructions.

Oasis Engineering Ltd. will not be held liable in such circumstances where installation, operation and maintenance procedures were performed by incompetent personnel resulting in improper assembly, unsafe operation, equipment damage or personal injury.

Oasis recommends that all service technicians should watch the Product Servicing Video before attempting to service this part.



Servicing Video

Oasis Engineering Ltd
129 Birch Avenue, Tauranga, New Zealand.
T: +64 7 928 3808
E: info@oasisngv.com
W: www.OasisNGV.com



Instruction Manual

Warning!

High pressure gas and gas equipment can cause serious harm to both infrastructure and personnel if safety precautions are not followed.

Oasis recommends considering the use of the following PPE when working with high pressure along with any other site specific health and safety requirements:



Foot Protection



Hearing Protection



Safety Helmets



Hand Protection



Safety Glasses



Ensure the system is clean of debris, vented and isolated before any installation or servicing work is carried out.

Tools Required

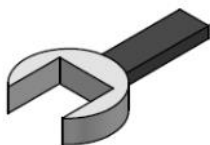

Spanners (Wrenches)

BV706 = 19mm, 50mm
BV708 = 19mm, 60mm



**Silicone Grease
(Rocol MX22 or similar)
For all O-rings**



Anti Seize Grease

- Swagelok Silver Goop
- Omega 99
- or similar



Spray bottle
(Snoop or soapy water)

1. Position Code 62 end O-rings in grooves.

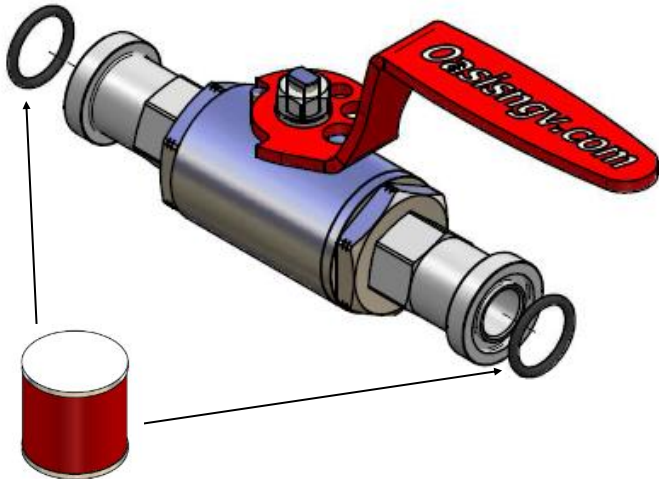

2. Loosely install one code 62 clamp for each end. Apply anti seize to bolt threads.

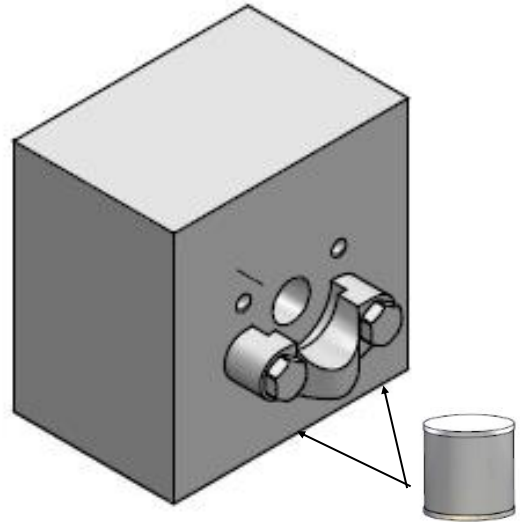

Oasis recommends
black phosphate coated class 10.9 or
higher screws as per SAE J518-2.

3. Slide in the code 62 flange and locate in the clamp.

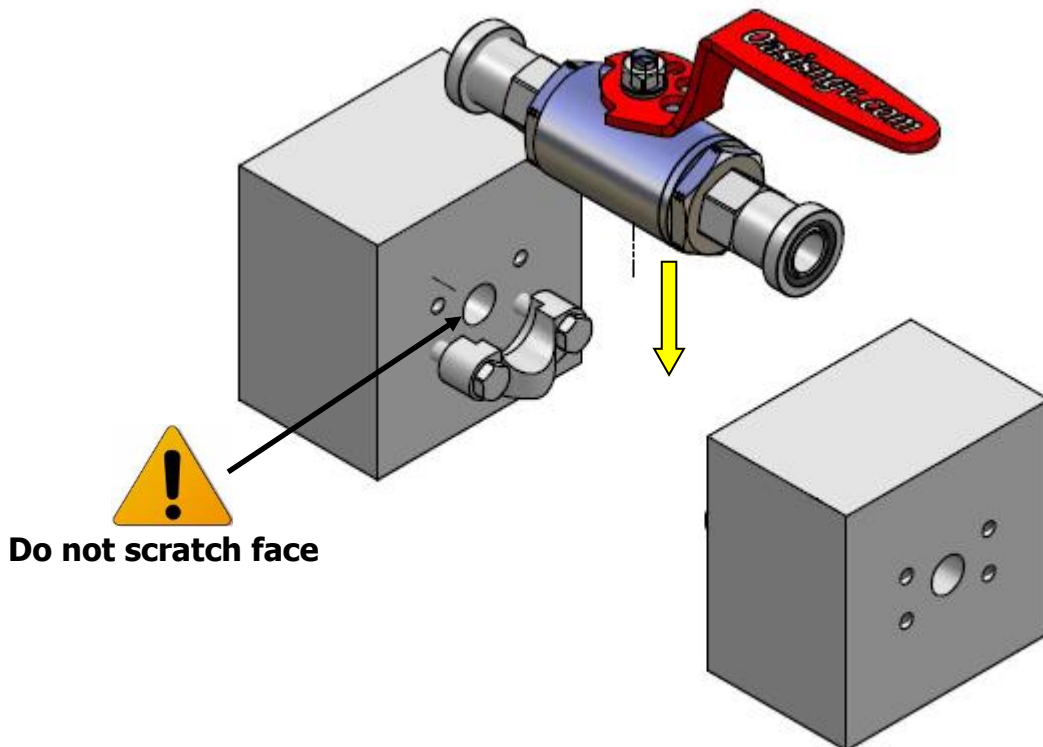

4. Install the remaining clamps, apply anti seize to bolt threads.

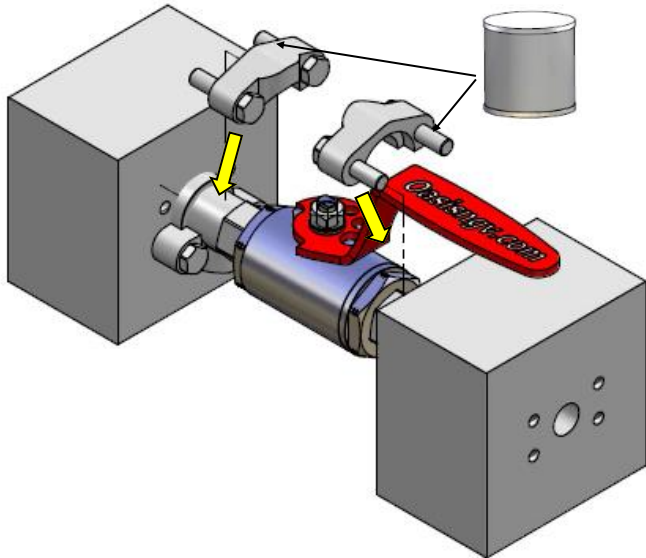

5. Torque the code 62 clamps to the clamp suppliers recommended torque.

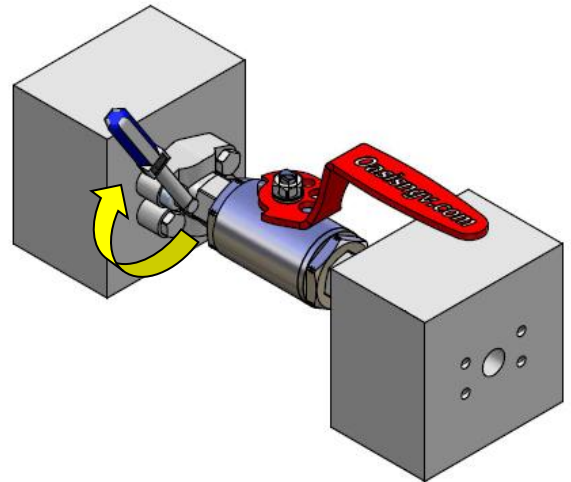

6. Leak test connection with Snoop or soapy water.

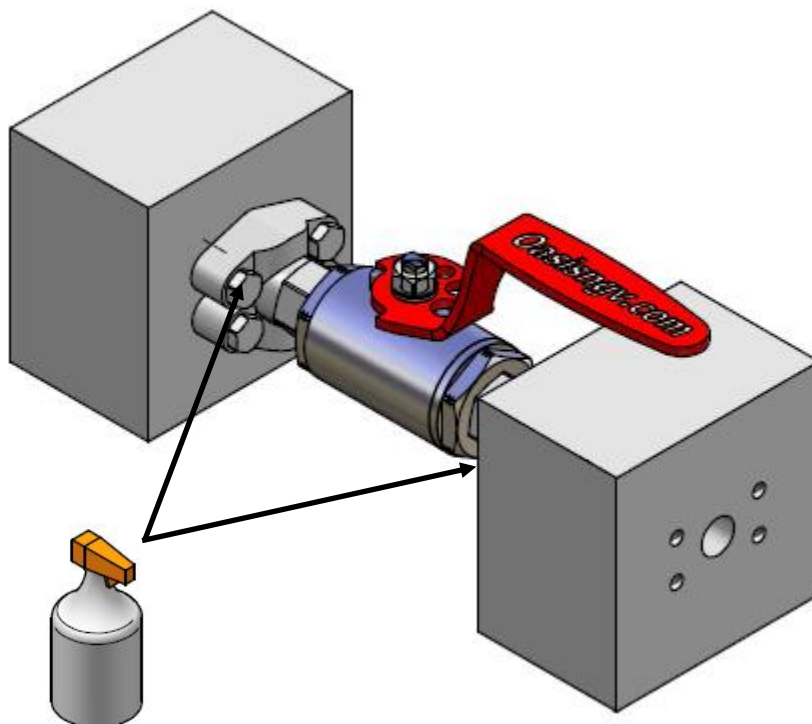

Important: Actuate valve 4 times before use to ensure initial sealing.

1. Closed.

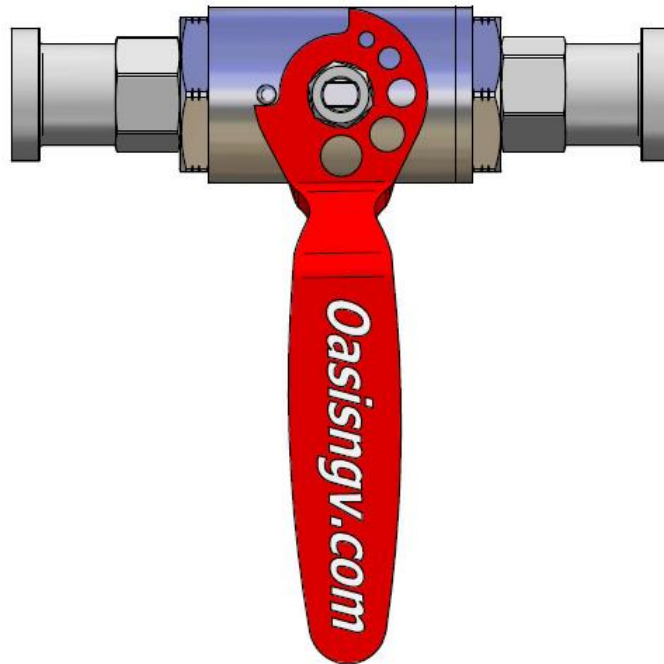

2. Open.

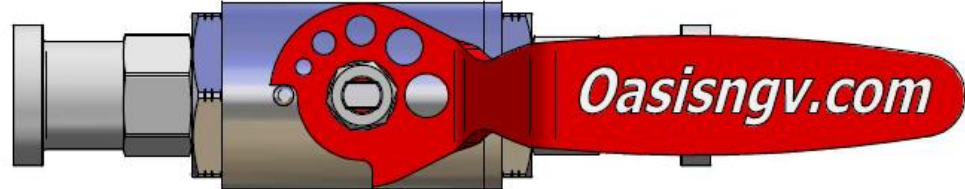

Important: Actuate valve 4 times before use to ensure initial sealing.

Service Kit Parts

2 x Seats ^



1 x Stem



1 x Ball**



1 x Gland



1 x Silicone



1 x Cap O-ring



1 x Locking Tab*



1 x Cap Backup O-ring



2 x SAE Fitting O-rings



(912 Nitrile 90)

2 x Code 62 O-rings



(214 Nitrile 90)

- only used when servicing actuated ball valves.
- ** It is normal for the service kit to include a ball with a small hole in the bottom
- ^ For low pressure service kits, seats will be supplied with an O-ring installed

The Complete Oasis Seal Kit must be used

Tools Required



Cleaner (Warm Soapy
Water or Similar)



Pick Tool
Part Number:
TOOL-PICK
(Sold separately)

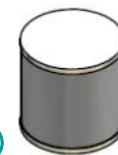

Anti Seize Grease
(Loctite 771 or Similar)
For All Threads

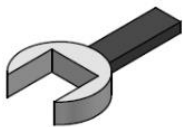

Spanners (Wrenches)
BV706 =
19mm, 50mm
BV708 =
19mm, 60mm

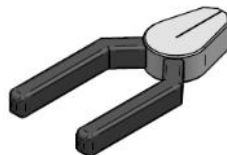

Pliers



Oasis Plastic Tool
Part Number:
TOOL-BVASSY
(Sold separately)
or Similar

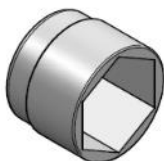

Sockets

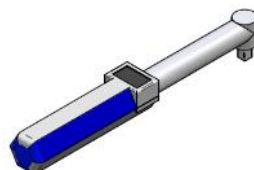

Torque Wrench



Spay bottle
(snoop or soapy
water)

1. Ensure the system is vented before removing the valve to be serviced.

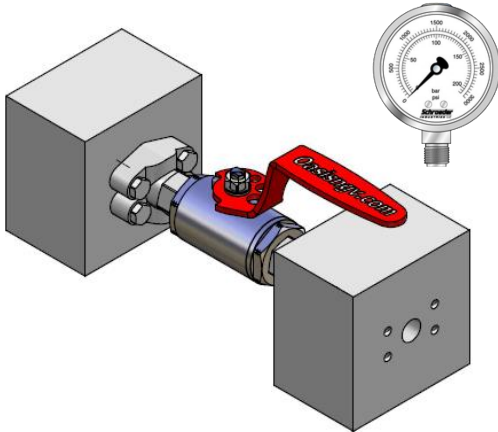

2. Loosen off the code 62 flange mounts.

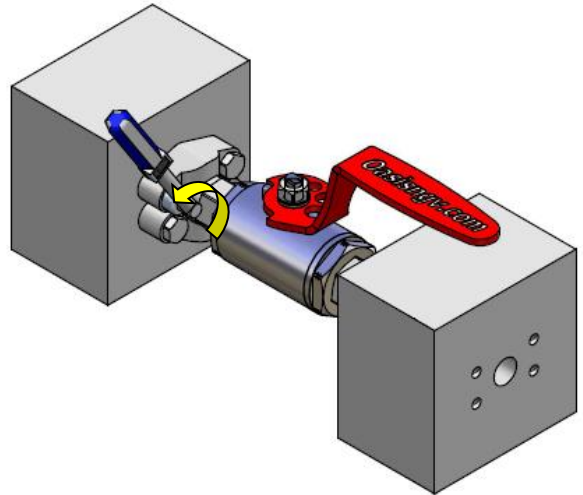

3. Remove code 62 flange mounts.

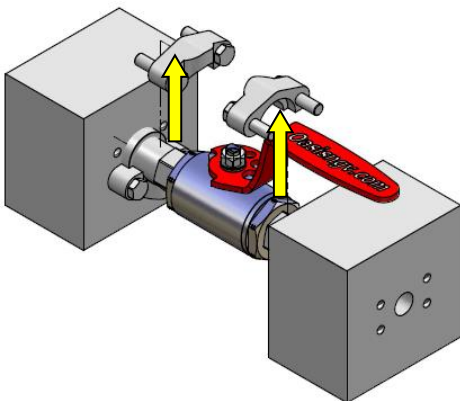

4. Remove the valve and move to a clean bench to service.

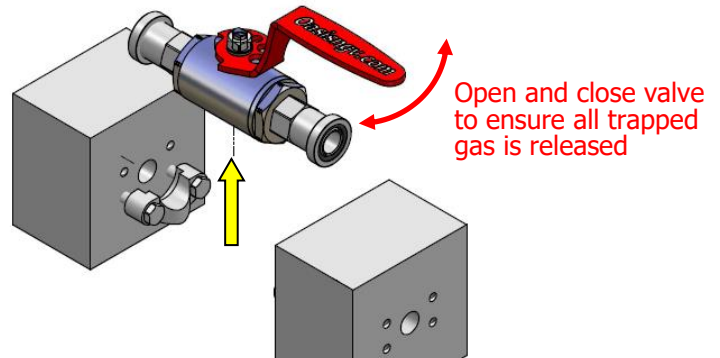

5. Remove Code 62 O-rings and discard.

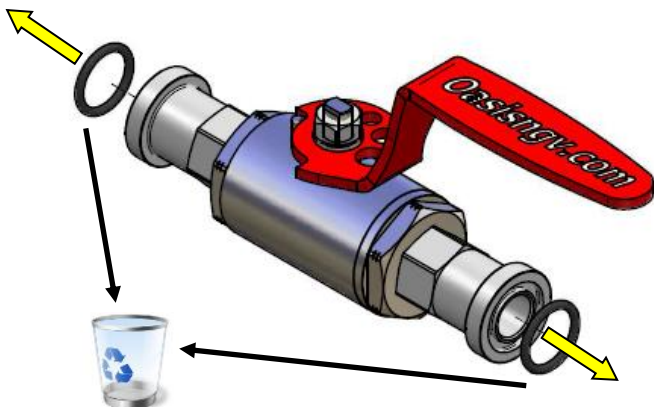

6. Remove one Code 62 adaptor, discard the SAE port O-ring.



6. If attached, remove one Code 62 adapter, discard the SAE port O-ring.

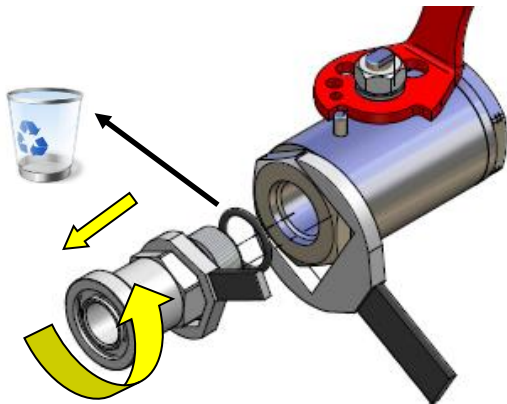

7. Remove the handle and discard the gland.

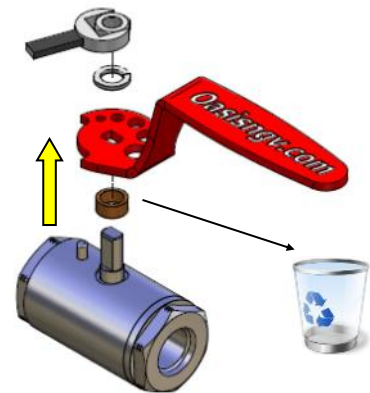

8. Remove the end cap.

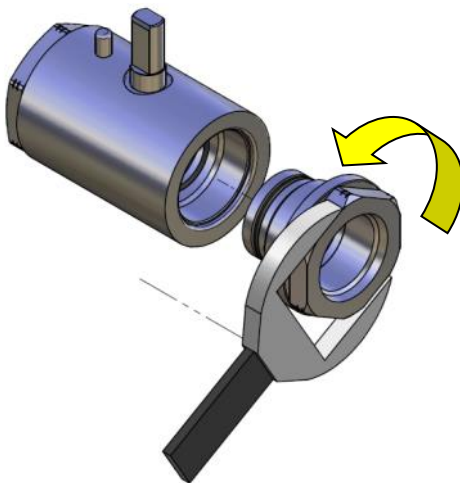

9. Remove the seat from the end cap and discard.

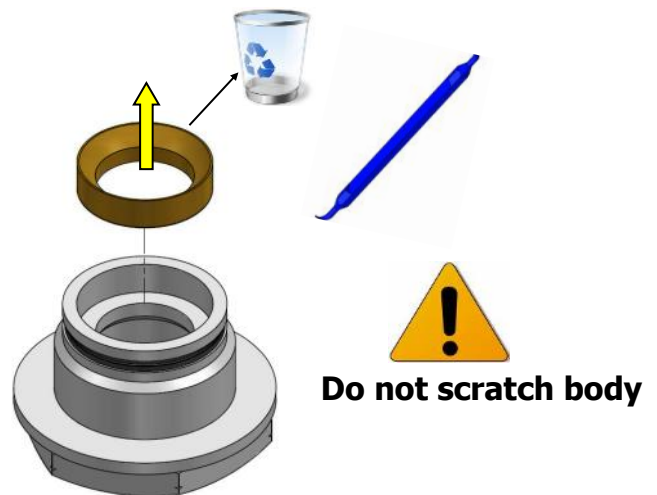

10. Remove the O-rings from the end cap and discard.

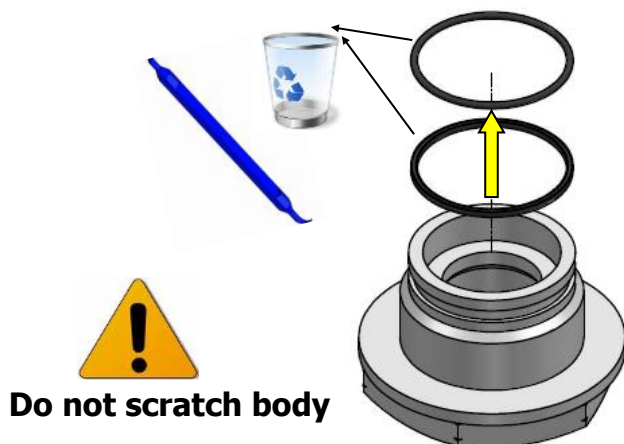

11. Remove ball and discard.



12. Remove the stem and discard.

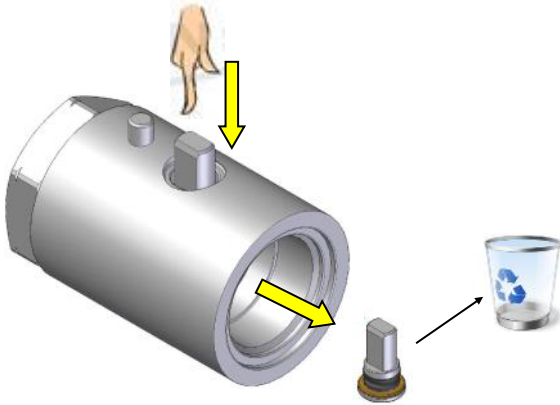

13. Remove the seat and discard.

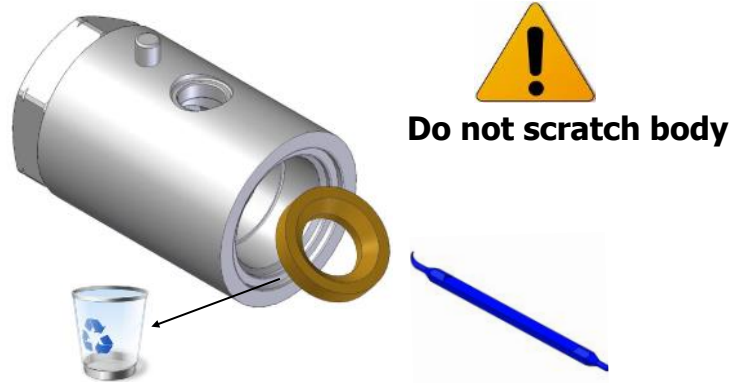

14. Clean all components. Visually check parts for damage.

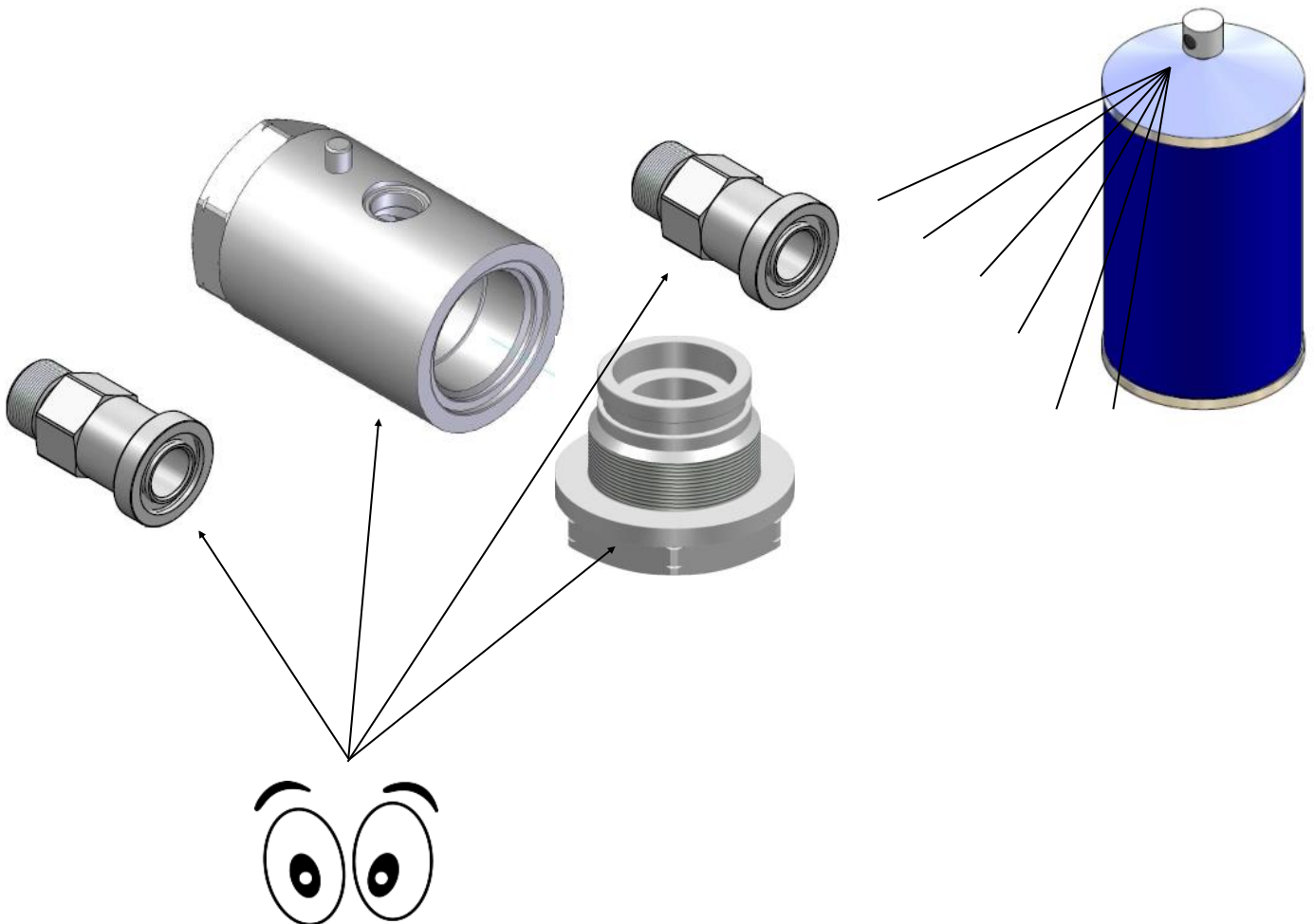

1. Install the O-ring and backup onto the cap.

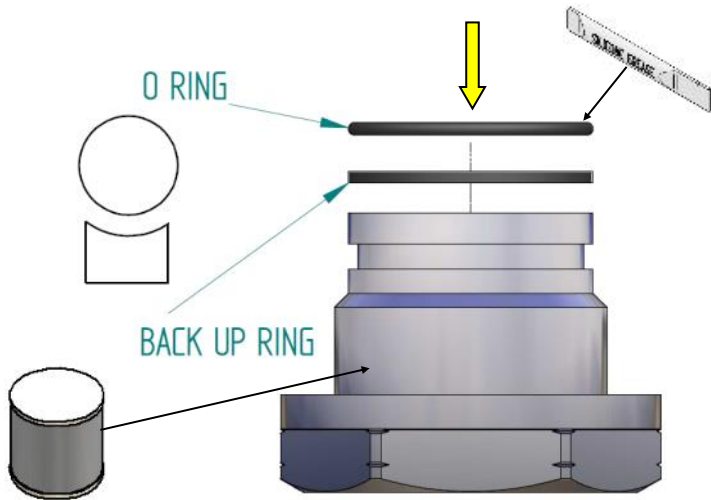

2. Apply silicone grease to new seat and install in cap. Take care not to pinch O-ring when installing low pressure seats.

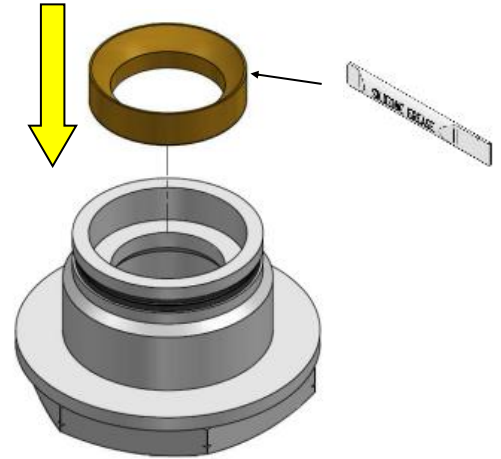

3. Apply silicone grease to back seat and install. Take care not to pinch O-ring when installing low pressure seat

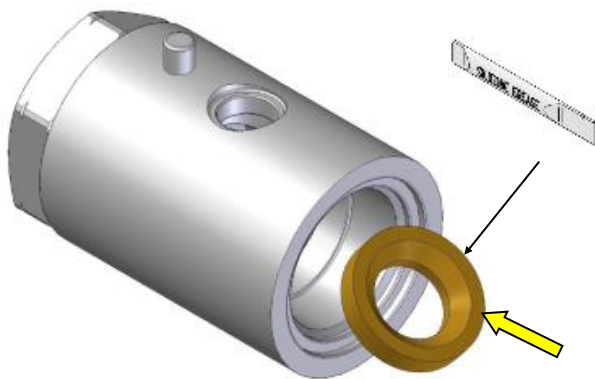

4. Insert the stem assembly.

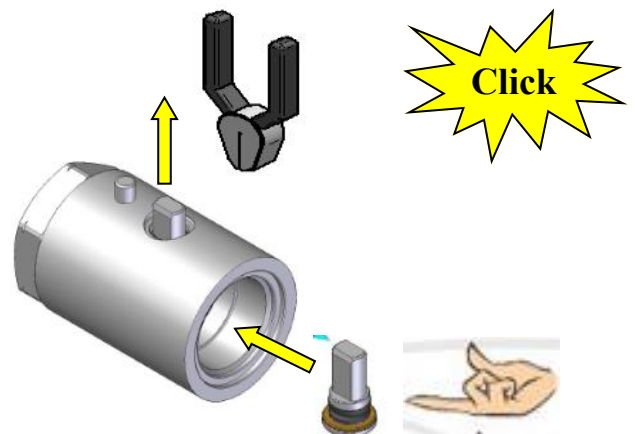

5. Insert the ball.

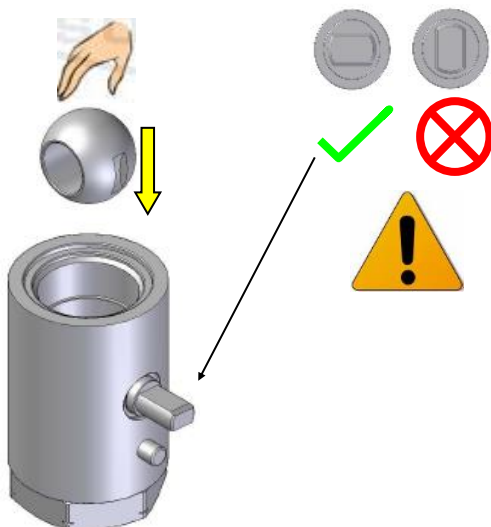

6. Torque on the end cap to 120Nm.

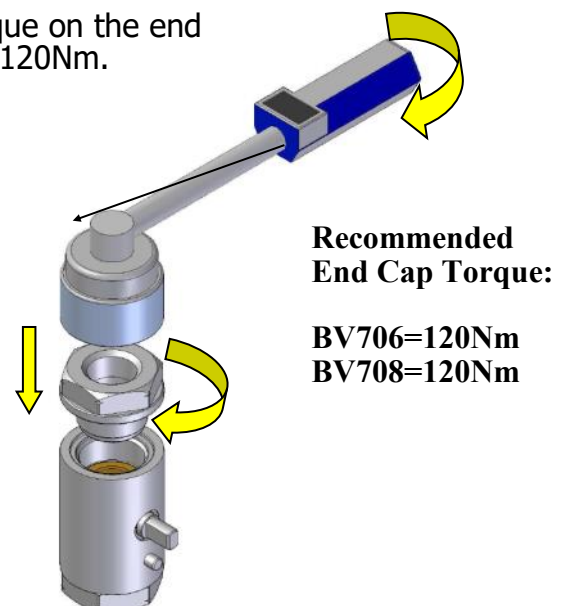

7. Insert the gland.

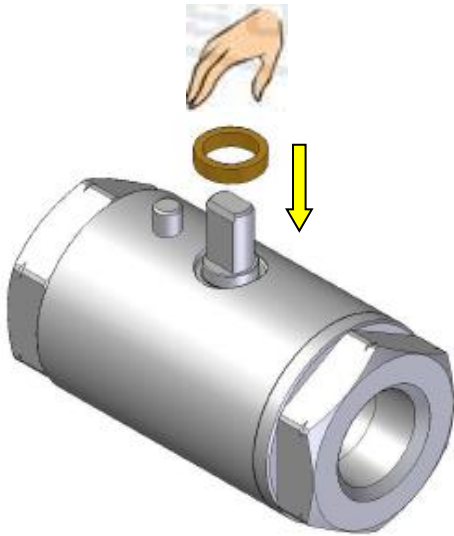

8. Install handle, spring washer and nut. Torque the handle nut to 6Nm.

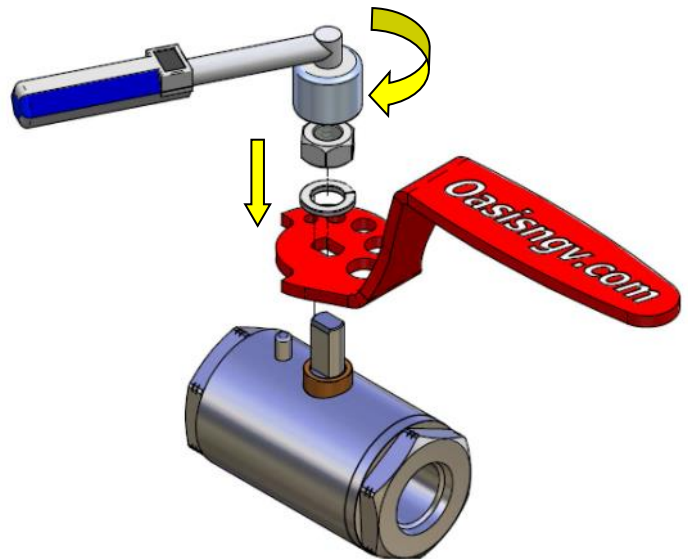

9. Install the first Code 62 adapter with O-ring and torque.

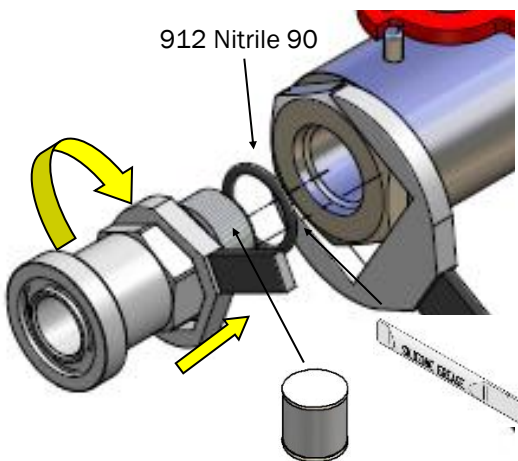

Recommended Torque:

BV706=140Nm
BV708=180Nm

10. Install the second Code 62 adapter with O-ring and torque. Servicing complete, reinstall as per the install instructions on page 3.

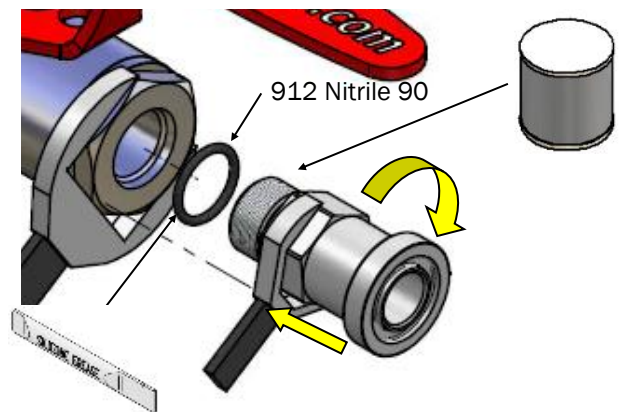

Recommended Torque:

BV706=140Nm
BV708=180Nm

Note: If using these instructions to service BV706-4X6ADDN or BV706-4Z6ADDN there should be one or two spare unrequired O-rings included in the service kit.