

# BV900 Series Ball Valve Tube Lock Instruction Manual

## **▲ WARNING**

Failure to follow these instructions or to properly install and maintain this equipment could result in gas leakage, fire or explosion causing property damage and personal injury or death.

Oasis products must be installed, operated and maintained by trained and competent personnel in accordance with all applicable local codes, rules and regulations in addition to the Oasis Instructions.

Oasis Engineering Ltd. will not be held liable in such circumstances where installation, operation and maintenance procedures were performed by incompetent personnel resulting in improper assembly, unsafe operation, equipment damage or personal injury.

Oasis recommends that all service technicians should watch the Product Servicing Video before attempting to service this part.

Oasis Engineering Ltd  
129 Birch Avenue, Tauranga, New Zealand.  
T: +64 7 928 3808  
E: [info@oasisNGV.com](mailto:info@oasisNGV.com)  
W: [www.OasisNGV.com](http://www.OasisNGV.com)



## Warning!

High pressure gas and gas equipment can cause serious harm to both infrastructure and personnel if safety precautions are not followed.

Oasis recommends considering the use of the following PPE when working with high pressure along with any other site specific health and safety requirements:



Foot Protection



Hearing Protection



Safety Helmets



Hand Protection



Safety Glasses



Ensure the system is clean of debris, vented and isolated before any installation or servicing work is carried out.

## Attention!

Oasis 900 series ball valves are intended for use with gaseous Hydrogen, CNG, Helium, Biogas or Nitrogen.

### Tools Required

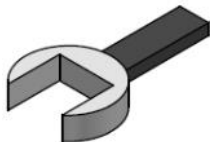

Spanner  
(Wrenches)



Anti Seize Grease  
- Swagelok Silver Goop  
- Omega 99  
- or similar



Silicone Grease  
(Rocol MX22 or similar)  
For all O-rings



Spray bottle  
(Snoop or soapy water)

1. Fit tube to inlet of valve.

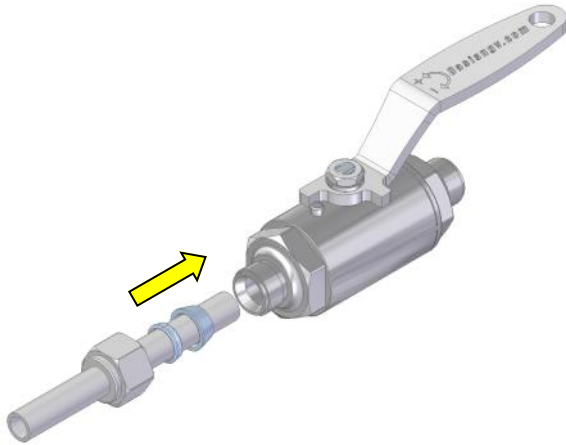

2. Apply anti-seize grease to port thread and push ferrule and nut up against it.

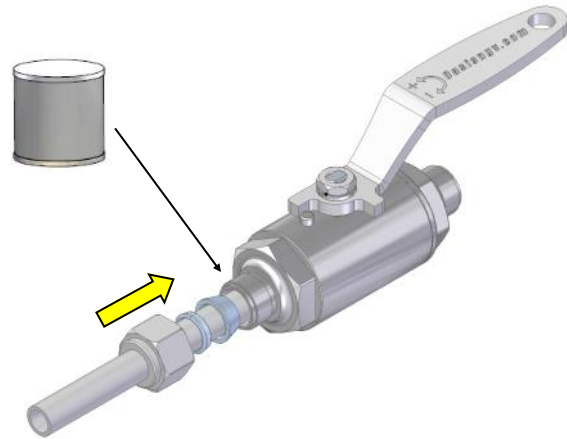

3. Hand tighten nut.

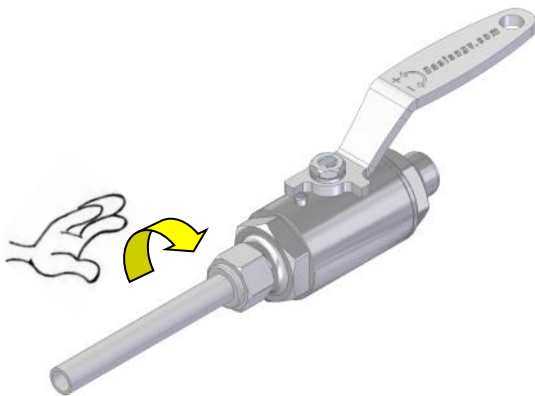

4. Tighten nut 1.5 turns past hand tight. Check with gauge if required.

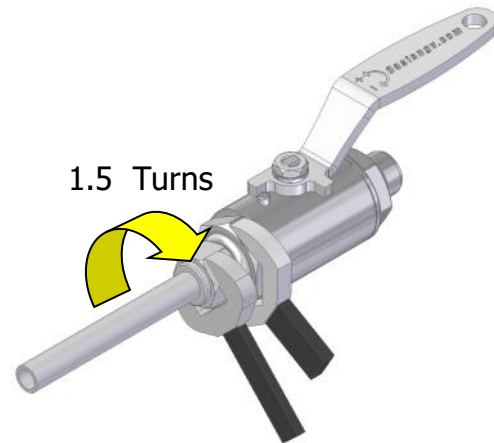

5. Repeat steps 1 to 4 on the other port.

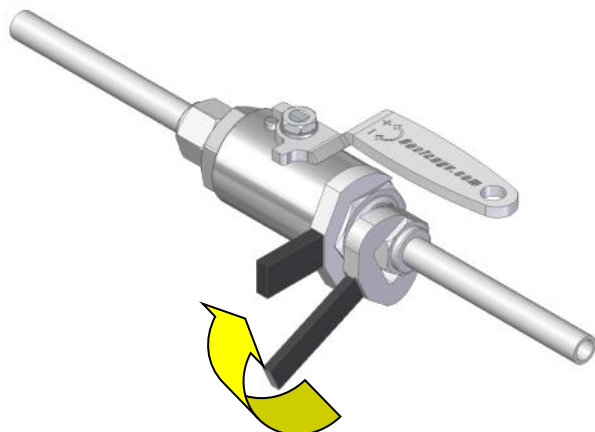

6. Installation complete, check for leaks on first use with snoop or soapy water.

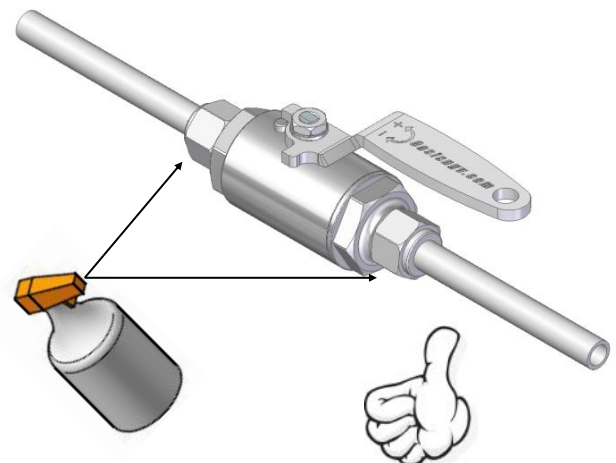

1. Closed



2. Opened



**Important:** Actuate valve 4 times before use to ensure initial sealing.

Optional - Lock-plate &  
Carabiner In Closed Position

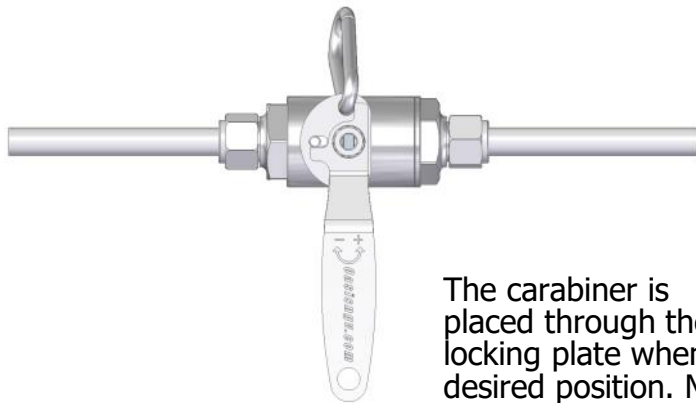

Optional - Lock-plate &  
Carabiner In Open Position



The carabiner is placed through the available hole on the locking plate when the handle is in the desired position. Movement of the handle is prevented until carabiner is removed.

### Recommended Spanners for End Caps:

- BV902 = 34mm
- BV903 = 34mm
- BV904 = 34mm
- BV906 = 50mm
- BV908 = 50mm

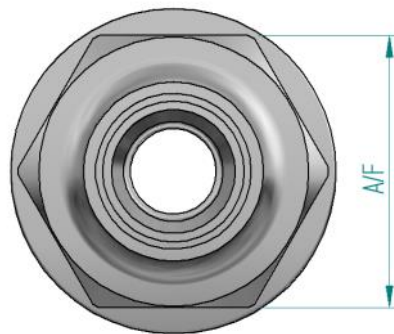

### Recommended Spanners for Stem Nuts:

- BV902 = 13mm
- BV903 = 13mm
- BV904 = 13mm
- BV906 = 19mm
- BV908 = 19mm

## Service Kit Parts

**BV902—BV903—BV904—BV906 — BV908**

2 x Seats



1 x Stem



1 x Ball



1 x Gland



1 x Silicone

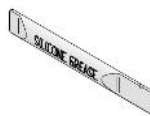

1 x Cap O-ring



1 x Locking Tab\*



1 x Cap Back-up O-ring



2 X SAE O-ring



\* Only used when servicing actuated ball valves.

**The Complete Oasis Seal Kit must be used**

## Tools Required

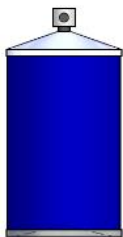

Cleaner (Warm Soapy  
Water or Similar)

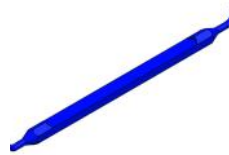

Pick Tool  
Part Number:  
TOOL-PICK  
(Sold separately)



Anti Seize Grease  
(Loctite 771 or Similar)  
For All Threads

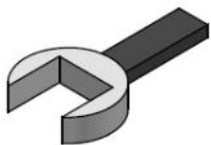

Spanner  
(Wrenches)

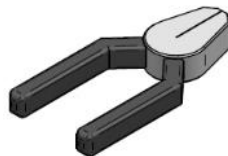

Pliers



Oasis Plastic Tool  
Part Number:  
TOOL-BVASSY  
(Sold separately)  
or Similar

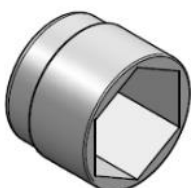

Sockets

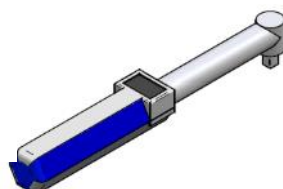

Torque Wrench

1. Unscrew stem nut.

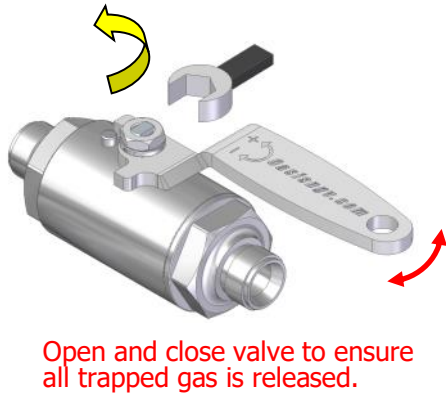

2. Remove handle.

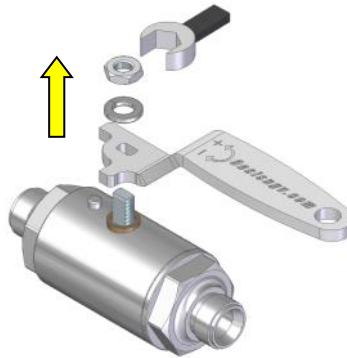

3. Discard gland.

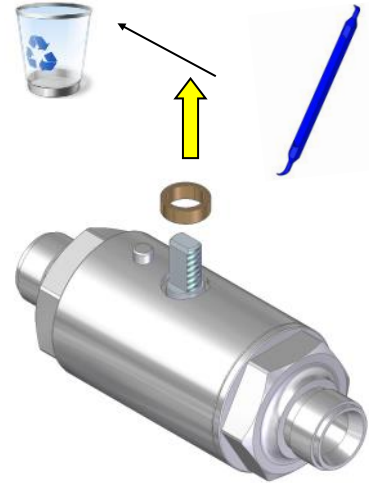

4. Remove end cap.



5. Discard seat.

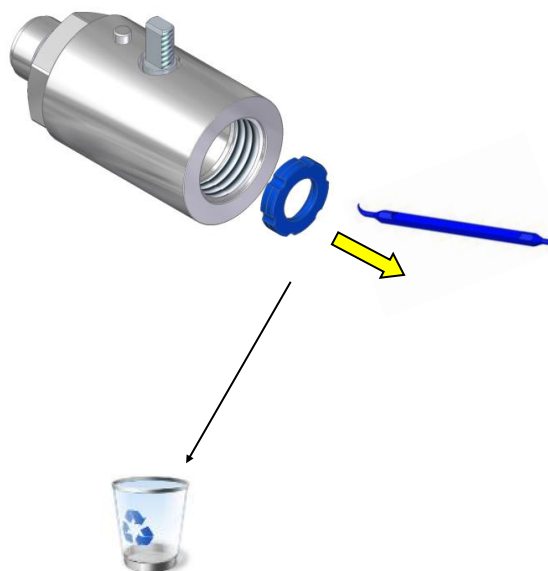

6. Remove ball.

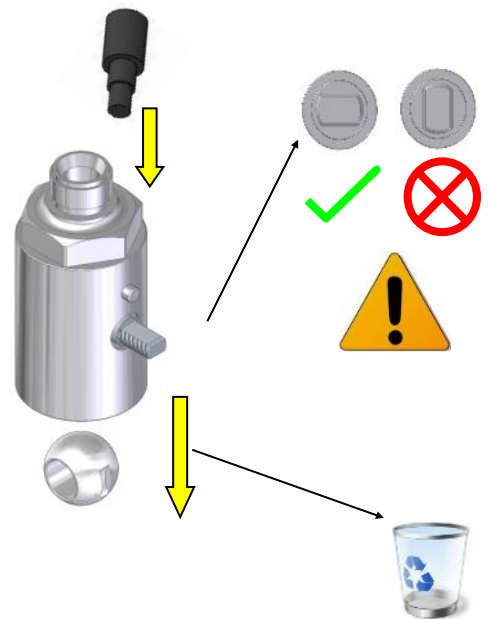

7. Remove stem first and discard.

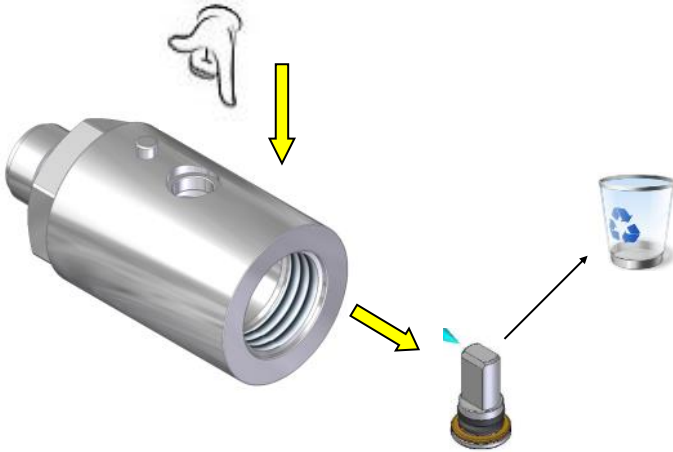

8. Remove and discard 2nd seat.

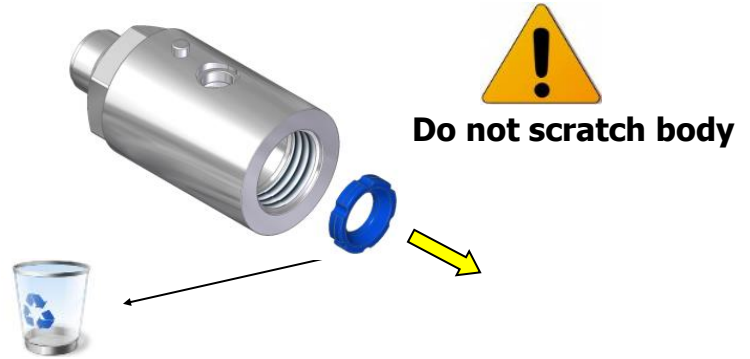

9. Remove cap O-rings and discard.

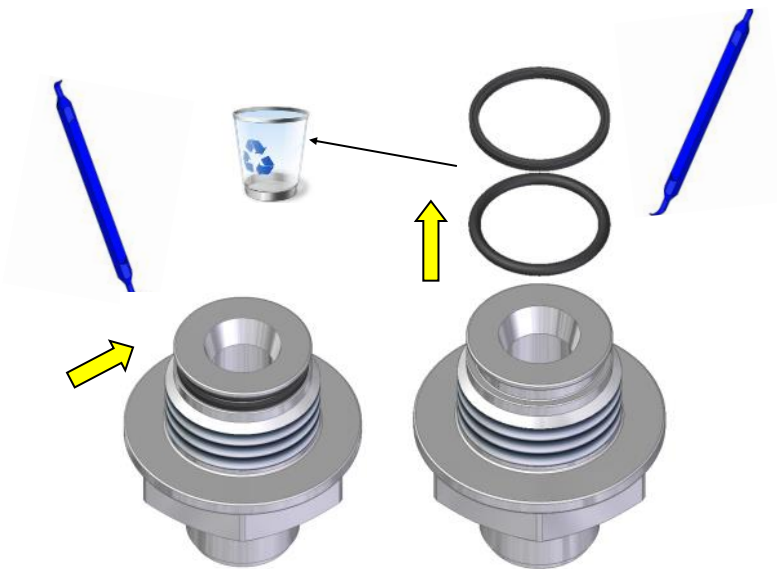

10. Clean body and end cap. Visually inspect parts for damage.

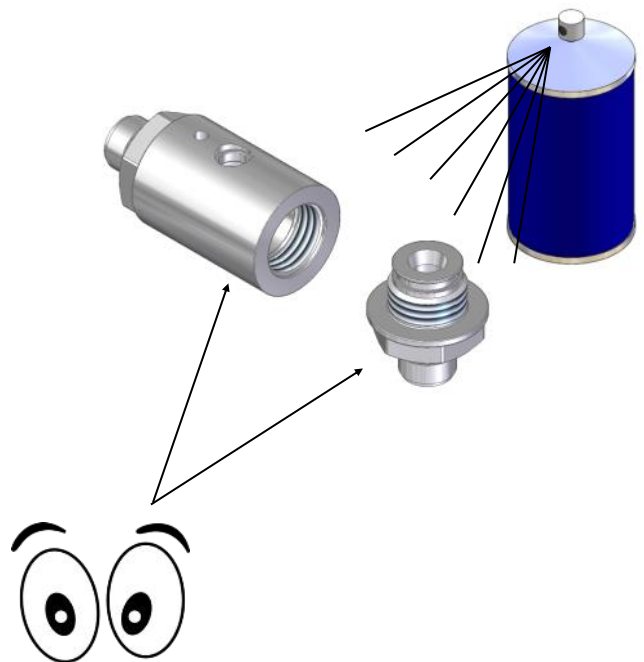

1. Apply grease to end cap o-rings and fit to end cap. Apply anti-seize to thread.

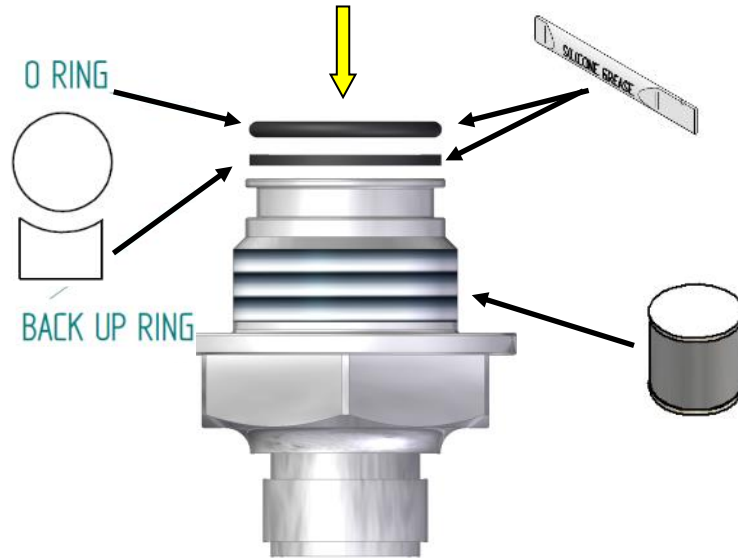

2. Install first new seat

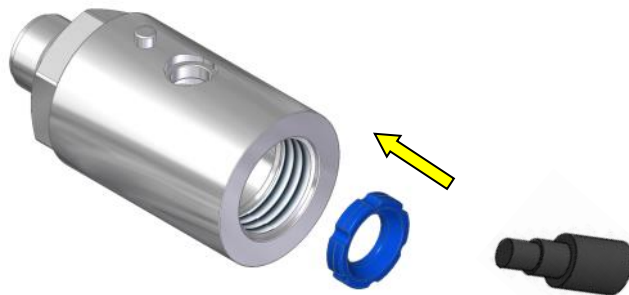

3. Apply grease to stem o-ring and insert stem assembly.

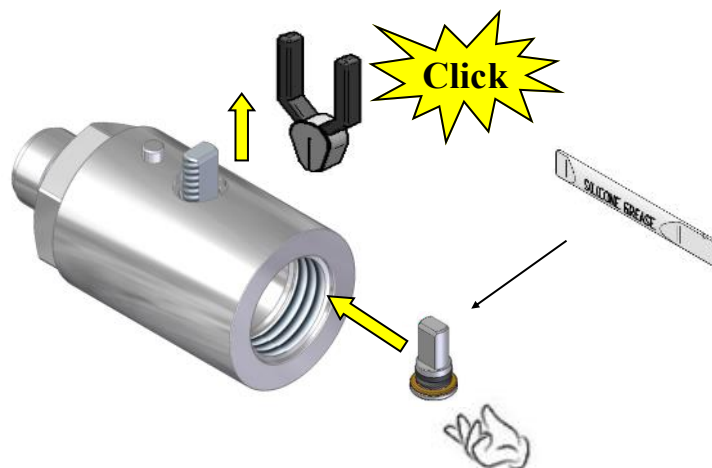



## 4. Insert Ball.

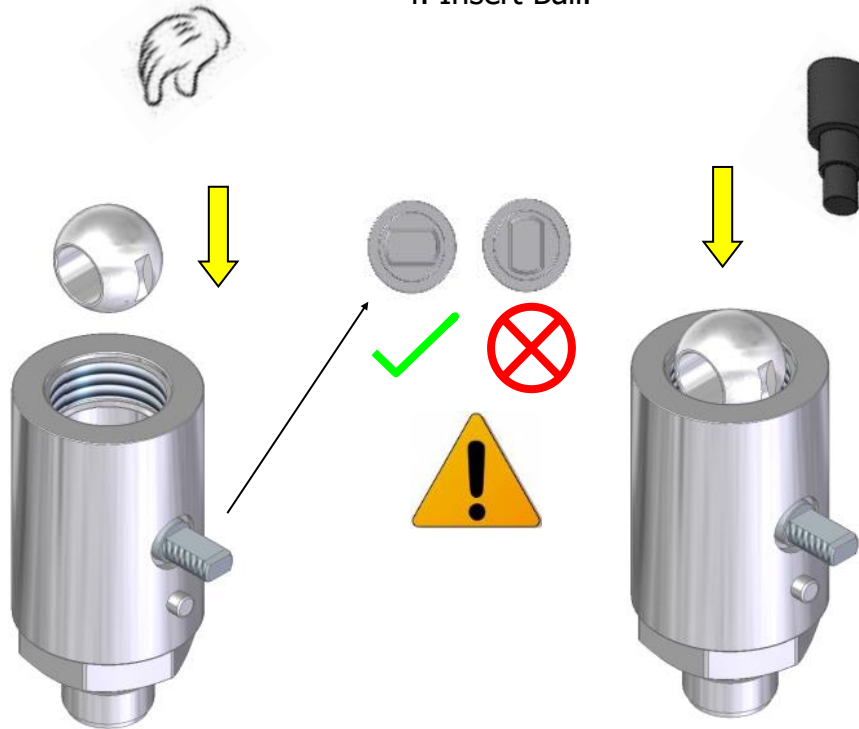

## 5. Install second new seat



6. Torque tight the end cap.

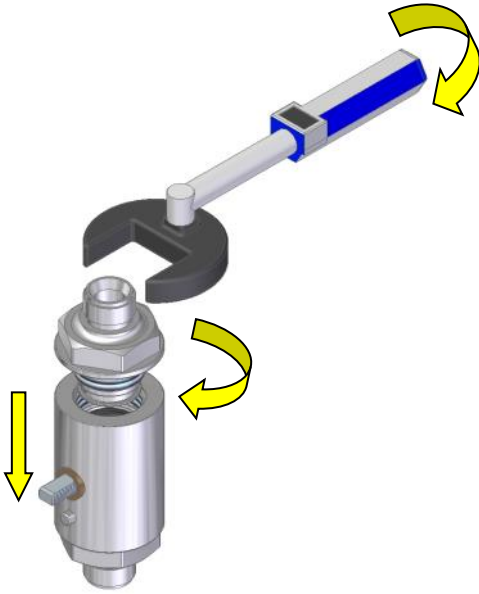

**Recommended  
End Cap Torques:**

BV902=60Nm  
BV903=60Nm  
BV904=60Nm  
BV906=160Nm  
BV908=160Nm

7. Install gland and screw on handle nut.

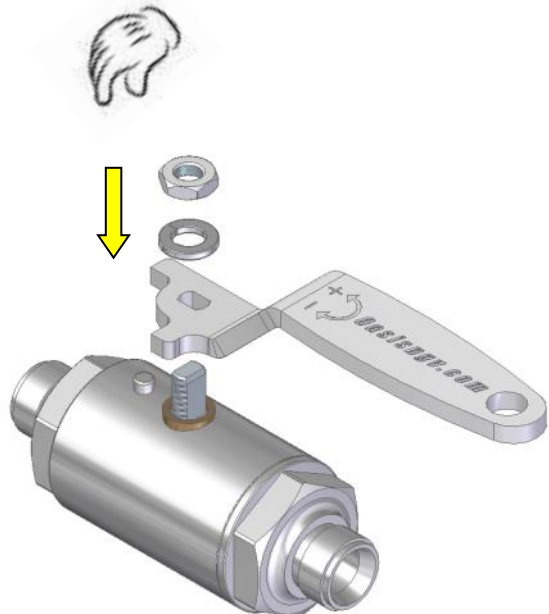
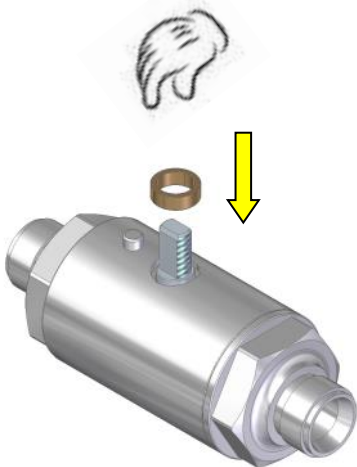

8. Tighten stem nut.

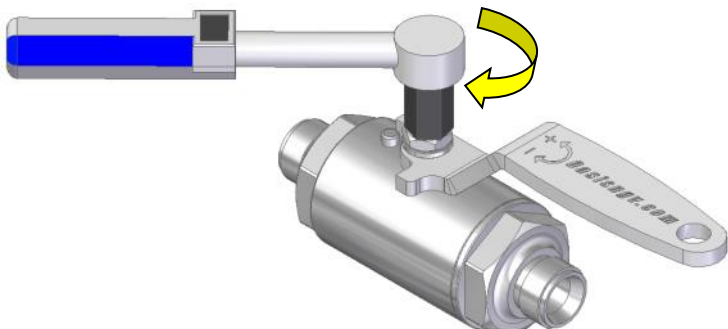

**Recommended  
Handle Nut Torques:**

BV902=3Nm  
BV903=3Nm  
BV904=3Nm  
BV906=6Nm  
BV908=6Nm

10. Insert tubes back into valve ports and tighten.

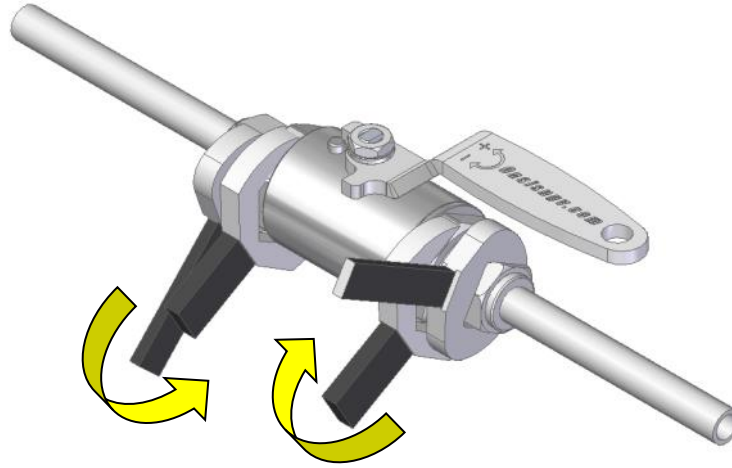

11. Servicing complete, check valve for leaks on first use with Snoop or soapy water.

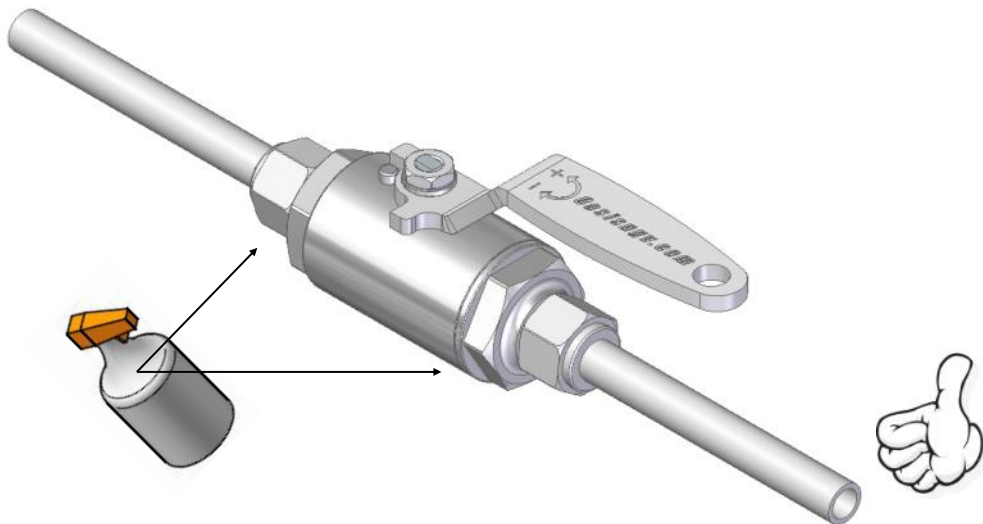

**Important:** Actuate valve 4 times before use to ensure initial sealing.