



# NC203

## NGV1 P30/P36 Nozzle

### Instruction Manual

ANSI/CSA NGV1-2006

#### **▲ WARNING**

Failure to follow these instructions or to properly install and maintain this equipment could result in gas leakage, fire or explosion causing property damage and personal injury or death.

Oasis NC203-P30/P36 Nozzles must be installed, operated and maintained in accordance with state, federal and local codes, rules and regulations and Oasis instructions.

Installation, operation and maintenance procedures performed by incompetent personnel may result in improper assembly or unsafe operation. Either condition may result in equipment damage or personal injury. Use competent personnel when installing, operating and maintaining the NC203-P30/P36 Nozzle.

Installation of this product shall conform to the requirements of authorities having jurisdiction or, in absence of requirements, with the standard for compressed natural gas (CNG) vehicular fuel systems, ANSI/NFPA 52, natural gas for vehicles installation code, CAN/CGA B149.4, or the natural gas installation code, CAN/CGA-B149.1, as applicable.



Servicing Video

Oasis Engineering Ltd  
129 Birch Avenue, Tauranga, New Zealand.  
T: +64 7 928 3808  
E: [info@oasisNGV.com](mailto:info@oasisNGV.com)  
W: [www.OasisNGV.com](http://www.OasisNGV.com)



Instruction Manual

## Warning!

**High pressure gas and gas equipment can cause serious harm to both infrastructure and personnel if safety precautions are not followed.**

**Oasis recommends considering the use of the following PPE when working with high pressure along with any other site specific health and safety requirements:**



Foot Protection



Hearing Protection



Safety Helmets



Hand Protection



Safety Glasses



**Ensure the system is vented and isolated before any installation or servicing work is carried out.**

## Tools Required



Anti Seize Grease



Silicon Grease

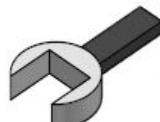

Spanners  
(wrenches)



Adaptor



243 Loctite  
Medium Strength

1. Ensure an O rings are installed on both sides of the adapter. Apply thread locker to both threads on the adaptor and screw into fill valve. Oasis recommends the FV103 fill valve.

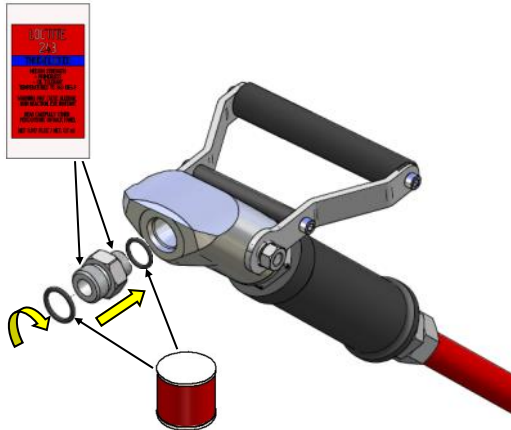

Torque to 70 Nm

2. Tighten the nozzle to the three way valve device.

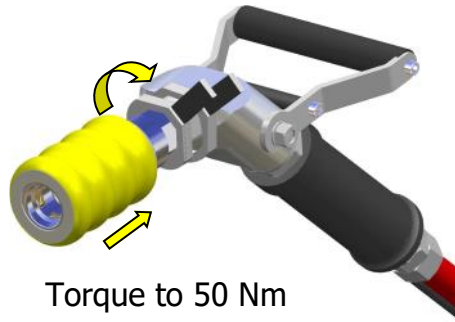

3. Slowly open the three way valve and test the fittings for leaks.

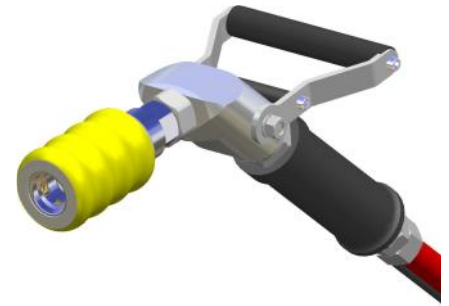

4. Hang the Nozzle up and ensure it is not left on the ground.



**CAUTION**

**A three way venting device must be used with this product to ensure it operates correctly. Oasis recommends the FV103 fill valve.**

**Ensure the product is hung up and remains free from damage.**



**CAUTION**

**When testing the valve, ensure the valve is held securely and opened slowly for the first time after servicing. If any leakage occurs then stop test and do not use nozzle. Contact Oasis for help.**

**Test for 1 minute**

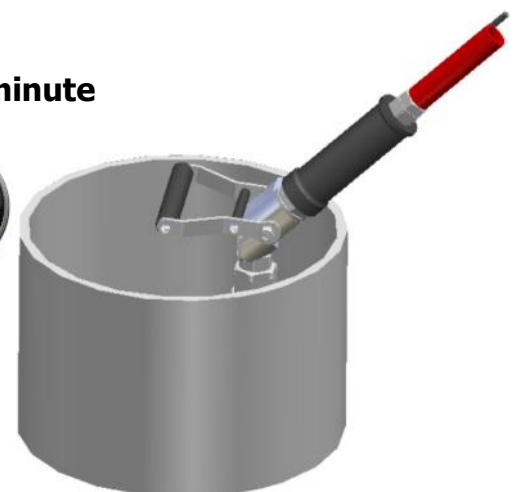

**(To test for leakage: Place nozzle in bucket of water with valve open and look for bubbles)**

1. Push the nozzle onto the receptacle.

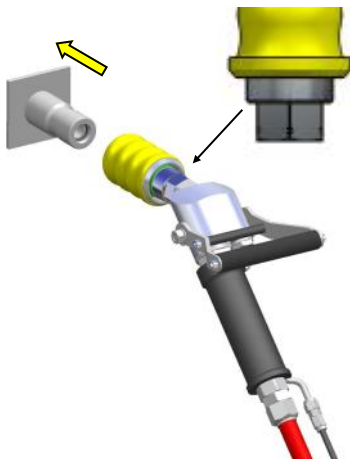

2. When coupled the nozzle will click into position and the green indication sleeve is visible.

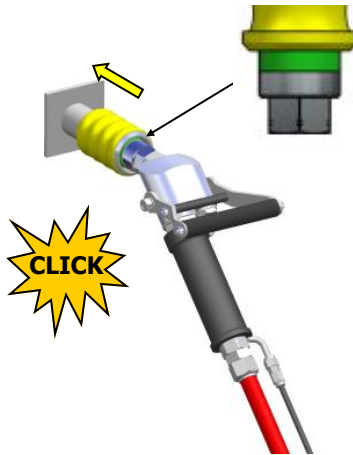

3. Open the handle on the fill valve to begin filling.

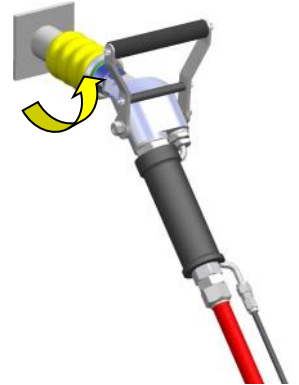

4. Close the handle when filling is complete to vent the nozzle.

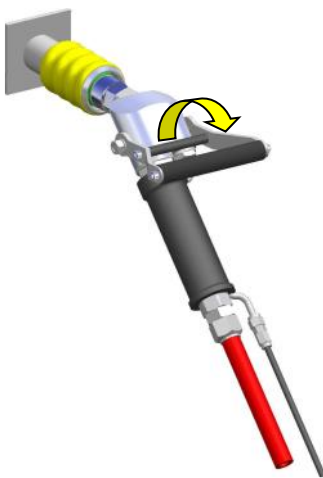

5. Pull back on the nozzle sleeve to disconnect the nozzle from the receptacle.

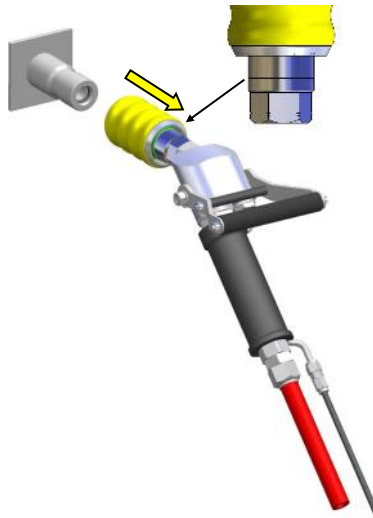

6. Return the nozzle to the holder and ensure it is not left on the ground.



7. Do not attempt to use the nozzle if the green sleeve is visible prior to connection.

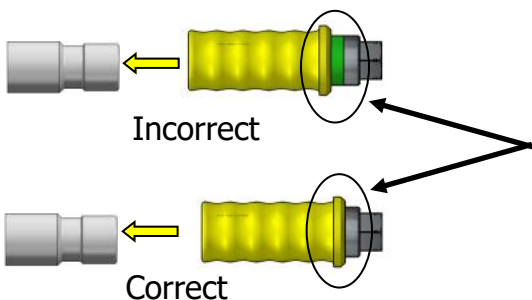

**Do not use the device if the green sleeve is visible when not connected to a receptacle. Contact Oasis Engineering if this happens. Failure to comply could result in property damage and/or personal injury.**

## Service Kit Parts



1x Cap Screw



4x Segments



4x Ball Bearings



1x Poppet Assembly



1x End Cap O-ring



1x Poppet Seal



1x Poppet Spring  
(32mm / 1.26" long)



1x Cap Spring  
(27.5mm / 1.08" long)



1x Sleeve Spring



1x Seal Retainer



1x Sleeve Locking  
Ring Clip



Silicone Grease  
ROCOL MX22 or similar  
(for all O-rings)



1x Inlet O-ring  
(906 NITRILE 90)



Thread Locker  
LOCTITE 243



TOOL-NC203

**The Complete Oasis Seal Kit must be used**

## Tools Required

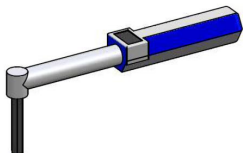

4mm Allen  
Key and Torque  
wrench

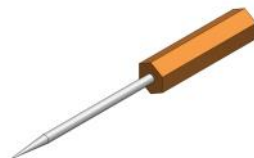

Sharp Pick  
Tool



Plastic Pick Tool  
Part Number:  
TOOL-PICK  
(Sold separately)

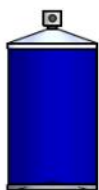

Cleaner (warm Soapy  
Water or Similar)



Anti Seize Grease  
(Loctite 771 or  
Similar)  
For All Threads

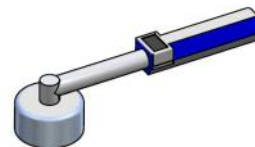

26mm  
Torque Wrench

1. Remove the sleeve locking ring clip using a sharp metal pick and discard.

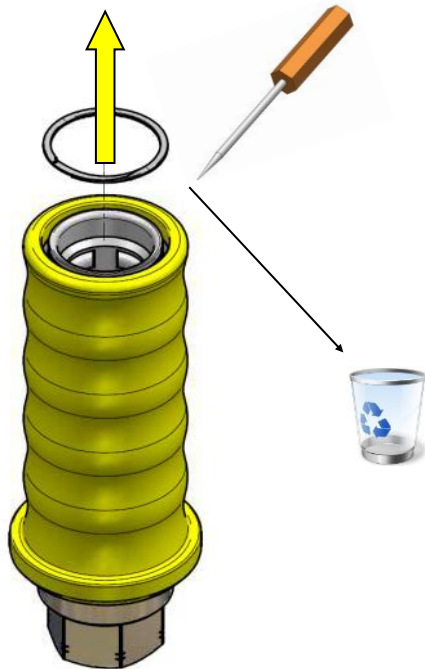

2. Push poppet down using either end of TOOL-NC203



3. Pull sleeve up to remove.

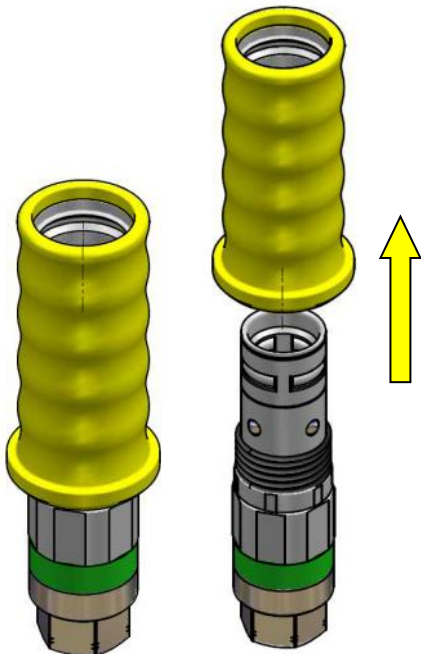

4. Remove and discard the segments, ball bearings and spring.

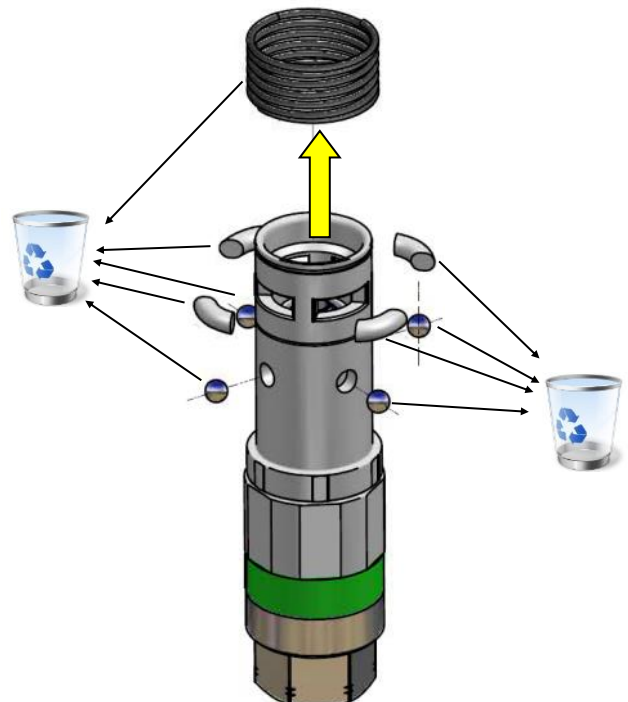

5. Undo the end cap by holding the body in a vice. Discard the poppet spring.

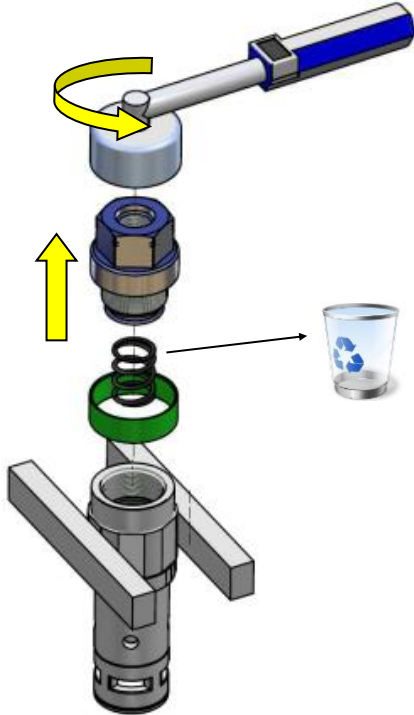

6. Place the TOOL-NC203 in the vice. Ensure correct direction for the poppet is used. Position the body over it so the poppet hex locates in the tool.

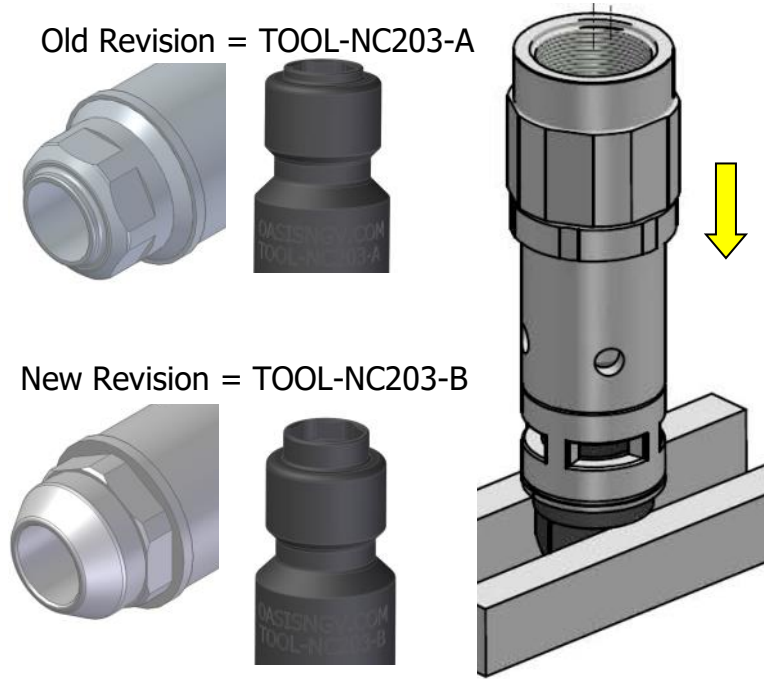

7. Hold down the body while undoing the internal cap screw.

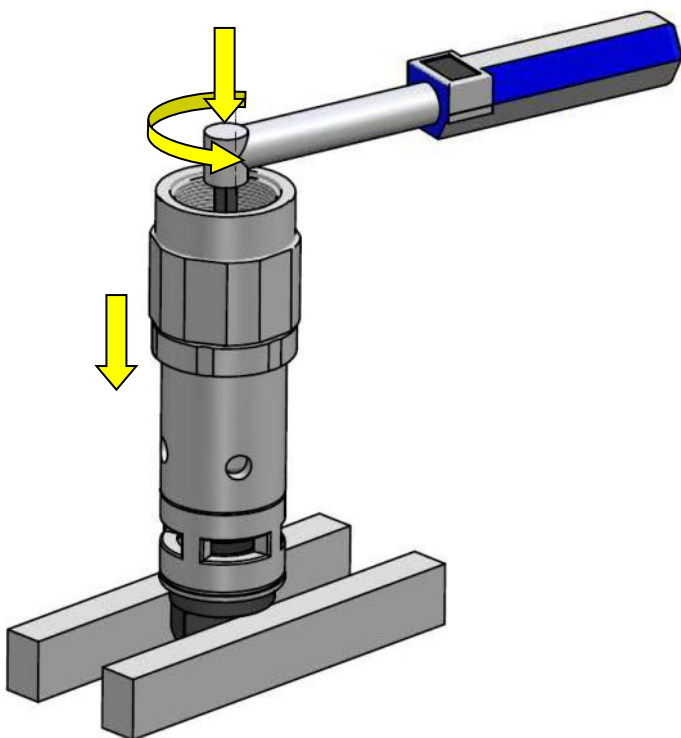

8. Discard the seal, seal retainer and the cap screw.

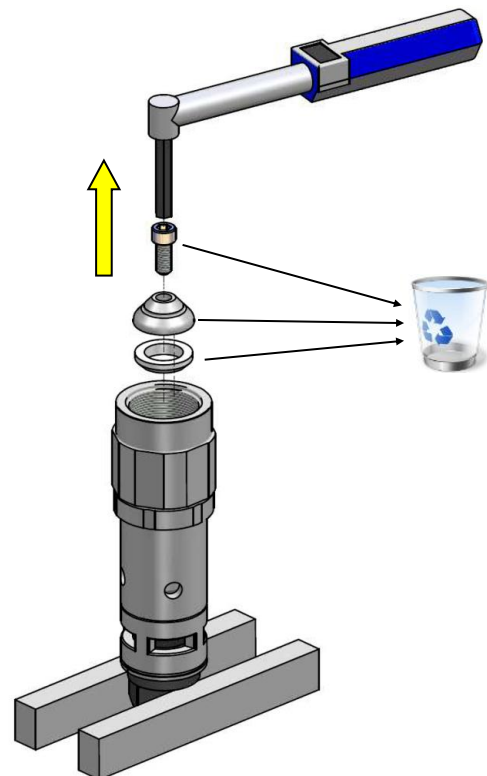

9. Remove the body and discard the poppet assembly and spring.

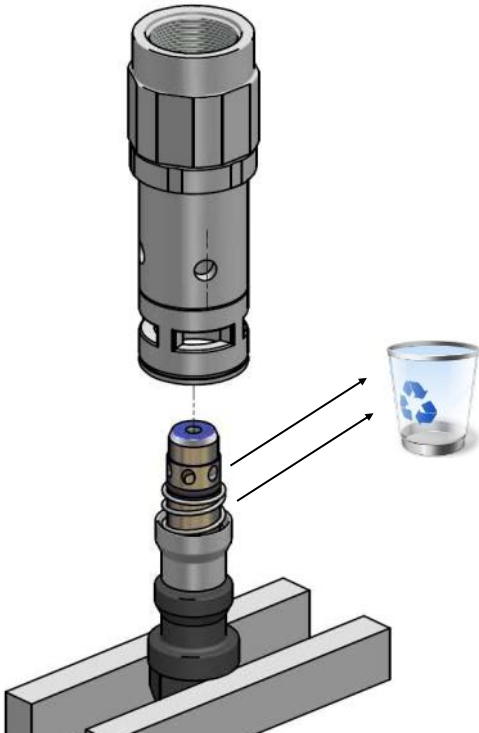

10. Remove end-cap O-ring and discard.

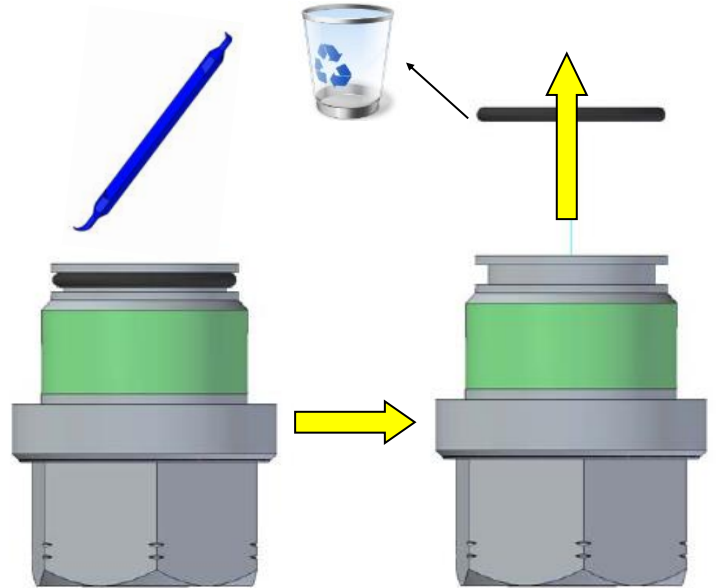

11. Clean and check components for excessive wear.

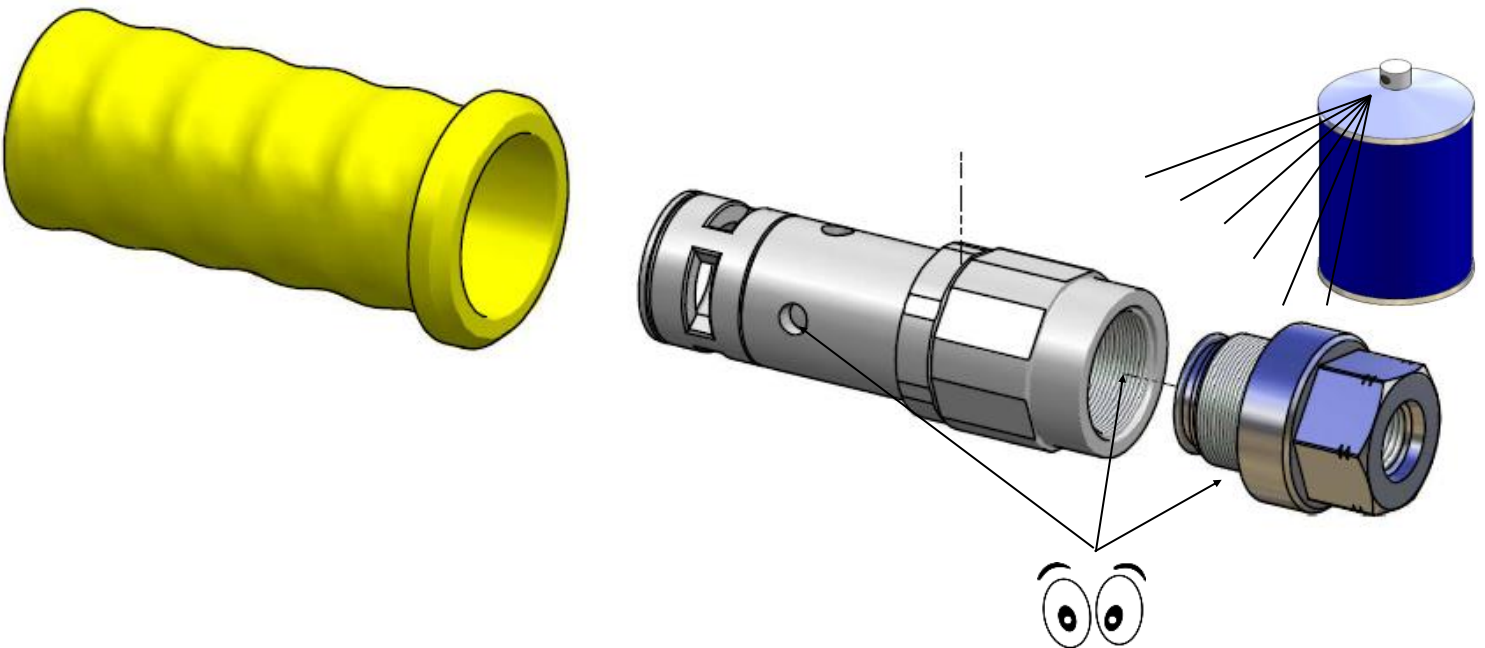



1. Apply silicone grease to the cap O-ring and install on the cap. Apply anti seize to the cap thread.

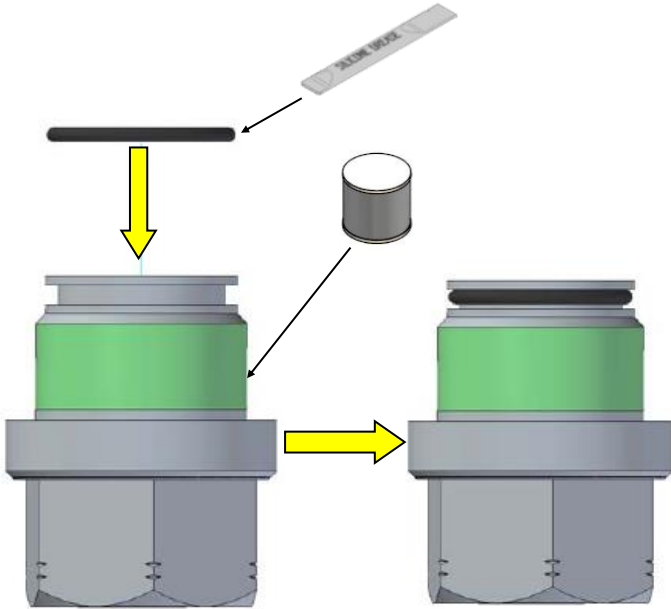

2. Install the poppet spring on the poppet

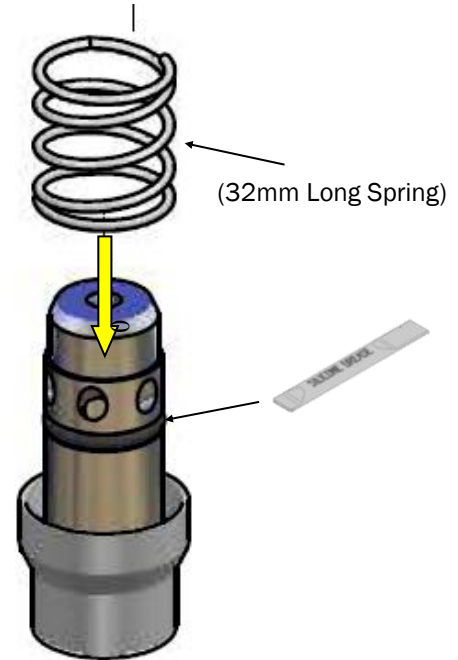

5. Apply Loctite to the poppet cap screw. Install the poppet seal, retainer and cap screw.

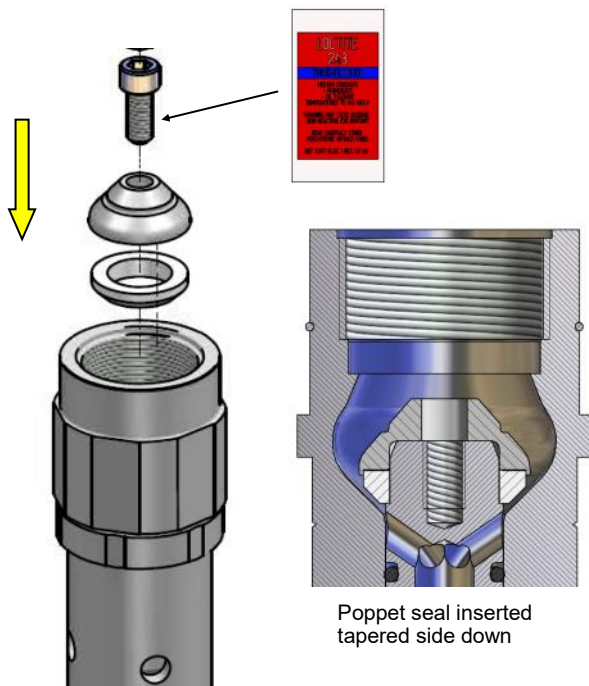

4. Place the TOOL-NC203 in a vice with the TOOL-NC203-B end facing up. Position the poppet, apply Loctite to the threaded hole and locate the body over the top.

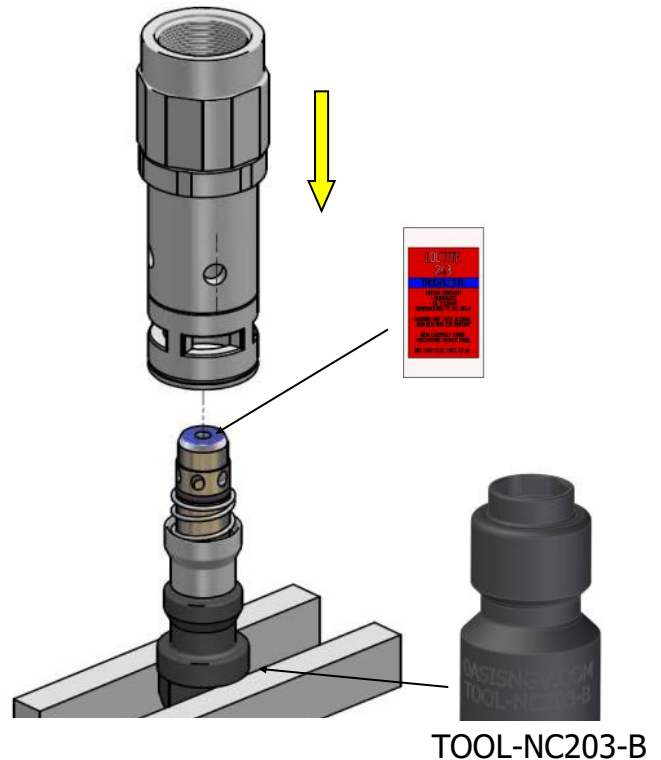

5. Tighten poppet cap-screw while pushing on bottom poppet assembly with TOOL-NC203-B.

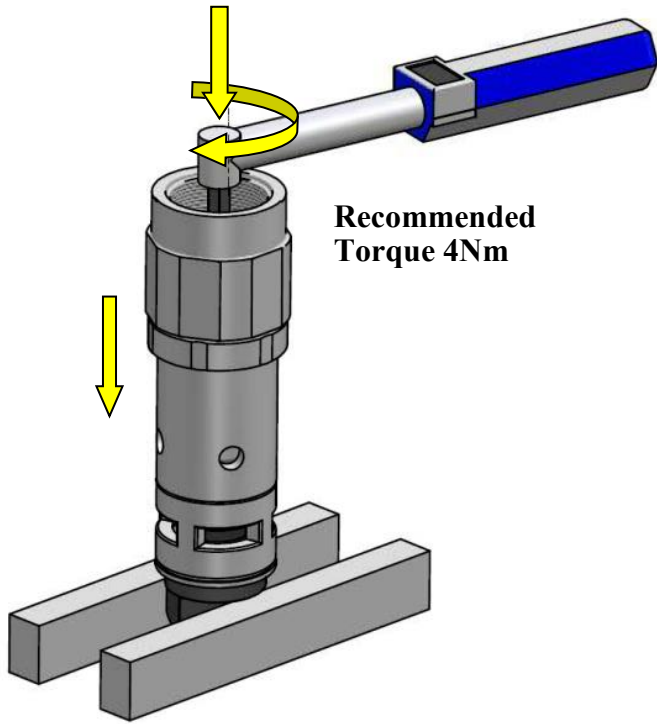

6. Install spring, green sleeve and tighten end-cap.

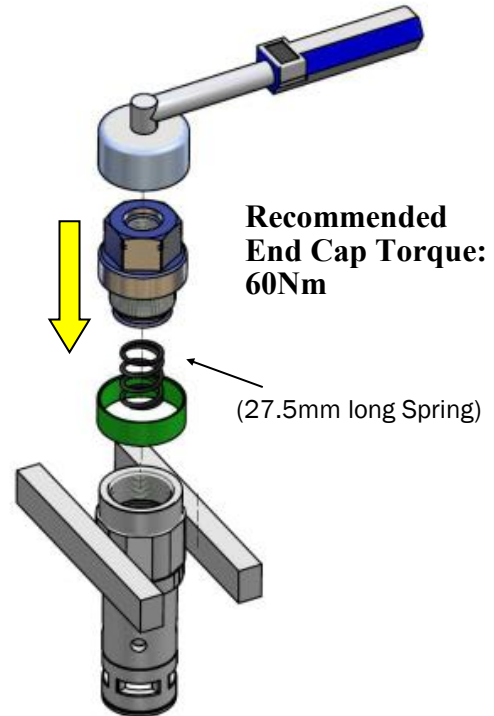

7. Install the TOOL-NC203-B and apply silicone grease to all ball bearing and segment holes. Install the ball bearings and segments.

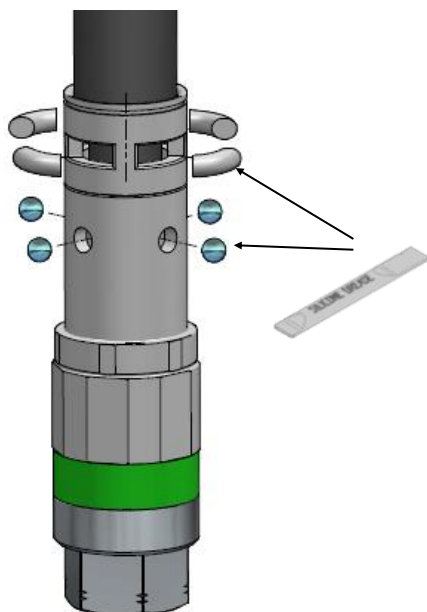

8. Install the sleeve spring so that it sits on the installed segments.



9. Position the sleeve.

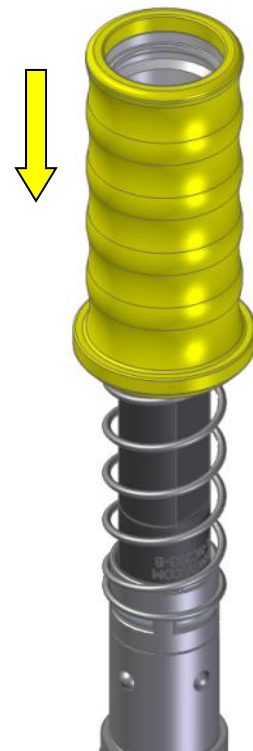

10. Use the TOOL-NC203-B to push down the internal poppet while pushing down the external sleeve.

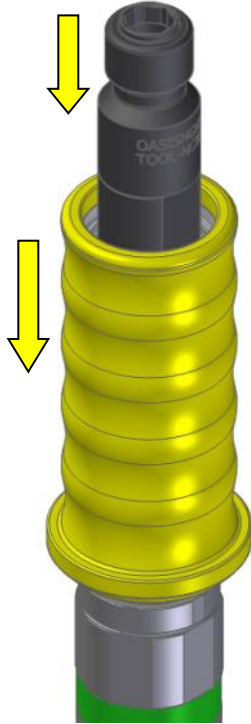

11. Remove the TOOL-NC203-B.



12. Open one edge of the new sleeve locking ring clip and install into the groove.

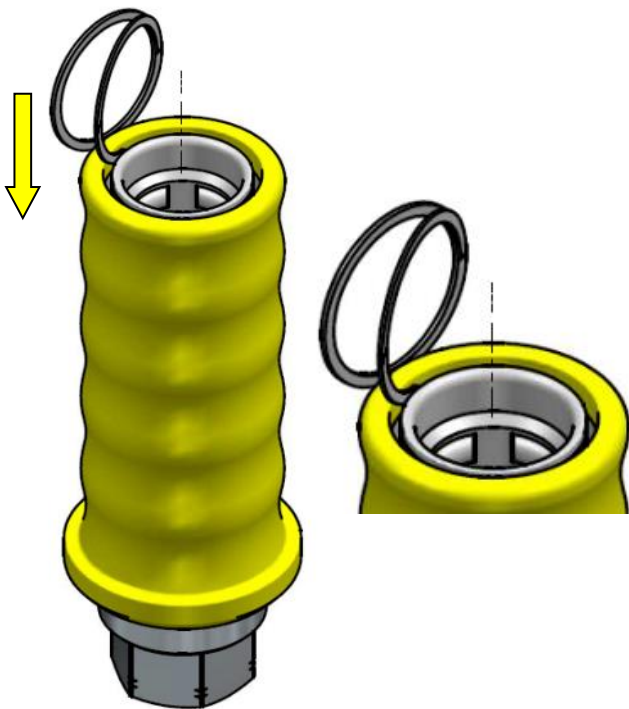

13. Bend over the clip and push into the groove.

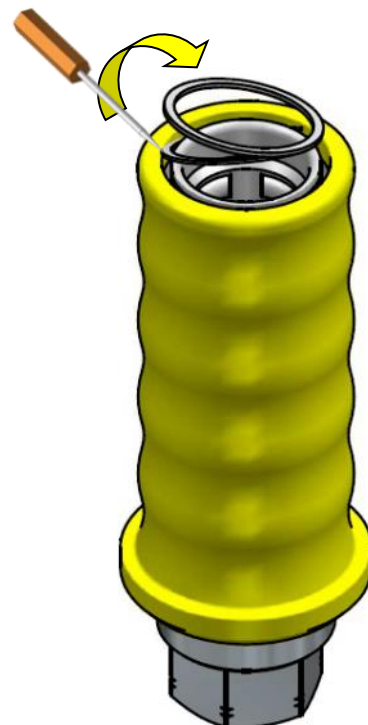

14. Check operation by inserting the TOOL-NC203-B or testing on a NGV1 receptacle. Follow the operation instructions on Page 4 if unsure of operation.

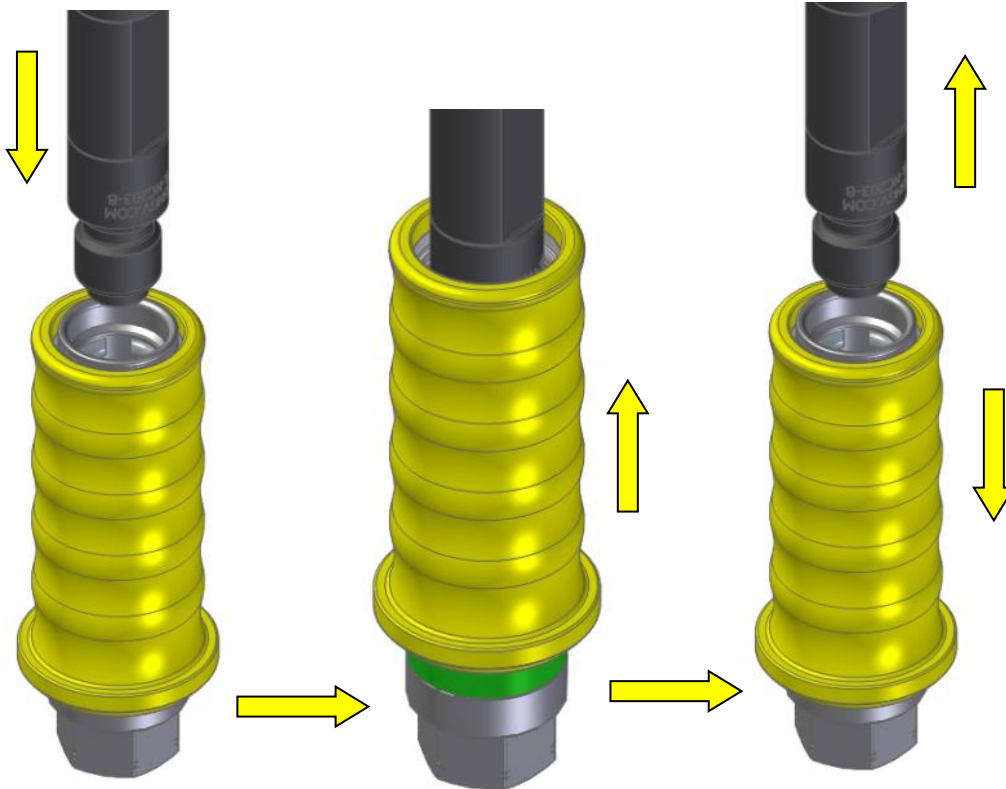

The sleeve should slide up when connected and the TOOL-NC203 should not be able to be removed until the sleeve is pushed back.

15. Follow the installation instructions on page 3 to re-install and leak test on first use.

